

SD

EOM

Surge Dampeners

Engineering
Operation &
Maintenance



Advance your process



SD $\frac{1}{2}$,
SD1,
SD2,
SD3

WILDEN[®]

A DOVER COMPANY



WIL-19010-E-03
REPLACES WIL-19010-E-01 & 02

THE EQUALIZER®

All reciprocating pumps experience a pressure fluctuation. The Equalizer® minimizes unwanted pressure fluctuation by providing a supplementary pumping action. This is accomplished by using a diaphragm as a separation membrane within the Equalizer® to trap a given volume of liquid on one side and pressurized air on the other. When the fluid pressure falls in the system, the Equalizer® supplies additional pressure to the discharge line between pump strokes by displacing fluid via diaphragm movement. This movement provides the supplementary pumping action needed to virtually eliminate pressure variation and pulsation.

The Equalizer® automatically sets and maintains the correct air pressure matching the variations in liquid flow or discharge pressure generated by the pump. A shaft attached to the Equalizer® diaphragm triggers the addition or deletion of the air within the non-wetted side of the Equalizer®. The Equalizer® automatically adjusts to any pressure and/or flow setting of the pump with no need for manual adjustment of the unit and/or system. The Equalizer® has proven to be the cost effective choice for protecting your liquid process system from unwanted pulsation or pressure fluctuation. Contact your local Wilden distributor for further information on the Equalizer® and other pumping solutions.

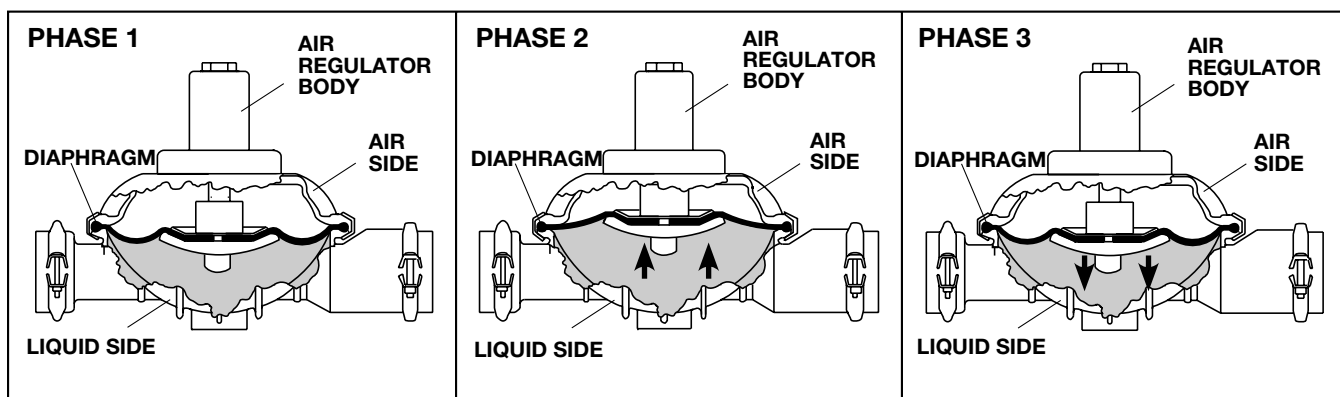

A compressed air line attached to the air regulator body sets and maintains pressure on the air side of the diaphragm. As the reciprocating pump begins its stroke, liquid discharge pressure increases which flexes the Equalizer® diaphragm inward. This action accumulates fluid in the liquid chamber (see

phase 2). When the pump redirects its motion upon stroke completion, the liquid discharge pressure decreases forcing the Equalizer® diaphragm to flex outward displacing the fluid into the discharge line (see phase 3). This motion provides the supplementary pumping action needed to minimize pressure fluctuation.

CAUTION: DO NOT EXCEED 125 PSIG AIR PRESSURE.

Maximum temperature limits are based upon mechanical stress only. Certain chemicals will significantly reduce maximum safe operating temperatures. Consult Wilden Chemical Guide for chemical compatibility and temperature limits.

Plastic Equalizers are manufactured with virgin plastic and are not UV stabilized. Direct sunlight for prolonged periods can cause deterioration of these plastics. In this situation a metal Equalizer® is suggested.

Wear safety glasses. When diaphragm rupture occurs, material being pumped may be forced out air exhaust.

WARNING

Prevention of static sparking — If static sparking occurs, fire or explosion could result. Pump, Equalizer®, valves, and containers must be grounded when handling flammable fluids and whenever discharge of static electricity is a hazard.

THE WILDEN EQUALIZER®

AUTOMATIC SURGE DAMPENER

BENEFITS:

- Minimizes pipe strain.
- Protects in-line equipment.
- Reduces water hammer.
- Absorbs acceleration head.
- Lowers system maintenance costs.

FEATURES:

- Clamp band construction for ease of maintenance.
- Automatically adjusts to any pressure and/or flow setting of the pump.
- Wide variety of materials to satisfy temperature and chemical compatibility considerations.
- Flow through design utilizing existing Wilden pump parts.
- Regulator Shaft controls the flex pattern of the diaphragm extending part life.
- Equalizer® utilizes a proven long-lasting Wilden diaphragm.

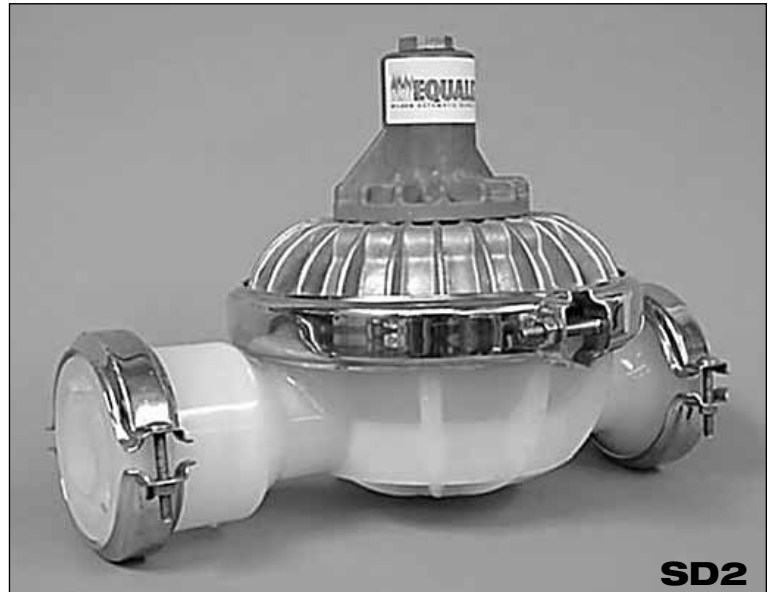

SD2



SD1

MATERIALS OF CONSTRUCTION:

Aluminum	Polypropylene
316 S.S.	PVDF
Cast Iron (SD1 and SD2)	Teflon® PFA (SD1)*
Carbon-filled Acetal	Teflon® PTFE (SD½)*

*All Teflon® Equalizers are assembled in a Class 10,000 Clean Room.

TEMPERATURE LIMITS FOR PLASTICS:

Polypropylene	+32 F (0 C)	to	+175 F (79.4 C)
PVDF	+10 F (-12.2 C)	to	+225 F (107.2 C)
Teflon® PFA	-20 F (-28.9 C)	to	+225 F (107.2 C)
Teflon® PTFE	-20 F (-28.9 C)	to	+225 F (107.2 C)

TEMPERATURE LIMITS FOR ELASTOMERS:

Neoprene	0 F (-17.8 C)	to	+200 F (93.3 C)
Buna-N	+10 F (-12.2 C)	to	+180 F (82.2 C)
Nordel®	-60 F (-51.1 C)	to	+280 F (137.8 C)
Viton	-40 F (-40 C)	to	+350 F (176.7 C)
Teflon®	+40 F (+4 C)	to	+220 F (104.4 C)



DAMPENING EFFECTIVENESS

The following bar charts highlight the effectiveness of the Equalizer® automatic surge dampeners. Pumps were operated at the stated air inlet pressures as the discharge pressure was then varied. The pulsation range was calculated from data points obtained using pressure transducers and an oscilloscope.

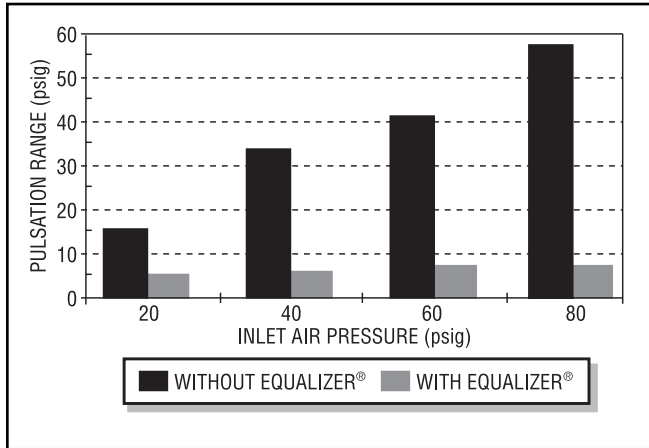

1/4" (6mm) pumps/SD1/2

The above chart reflects the discharge pressure variation of a Wilden model 1/4" (6mm) Polypropylene pump with rubber elastomers compared to the same 1/4" (6mm) with a model SD1/2 Equalizer® installed.

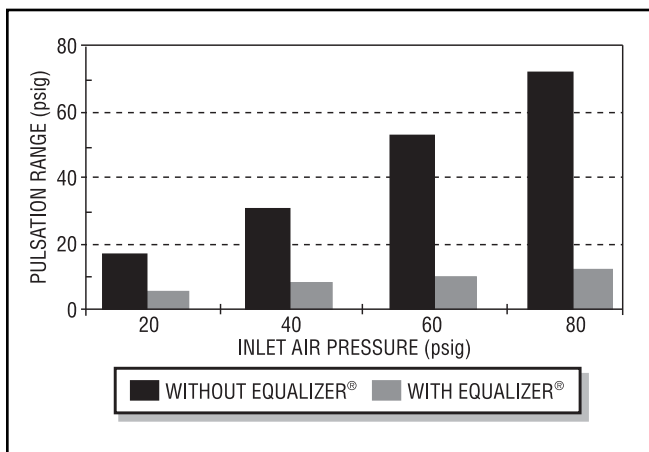

1/2" (13mm) pumps/SD1/2

The above chart reflects the discharge pressure variation of a Wilden model 1/2" (13mm) Polypropylene pump with rubber elastomers compared to the same 1/2" (13mm) with a model SD1/2 Equalizer® installed.

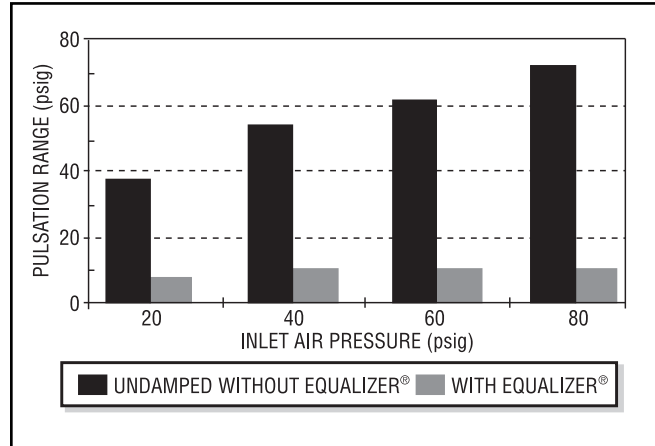

1" (25mm) pumps/SD1

The above chart reflects the discharge pressure variation of a Wilden model 1" (25mm) Polypropylene pump with rubber elastomers compared to the same 1" (25mm) with a model SD1 Equalizer® installed.

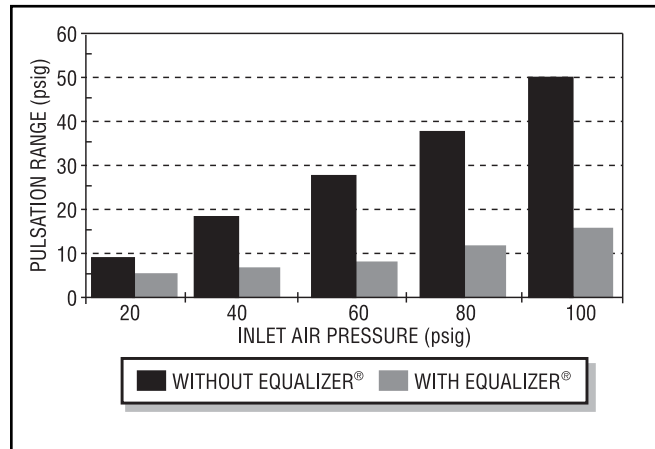

1 1/2" (38mm) pumps/SD2

The above chart reflects the discharge pressure variation of a Wilden model 1 1/2" (38mm) Polypropylene pump with rubber elastomers compared to the same 1 1/2" (38mm) with a model SD2 Equalizer® installed.

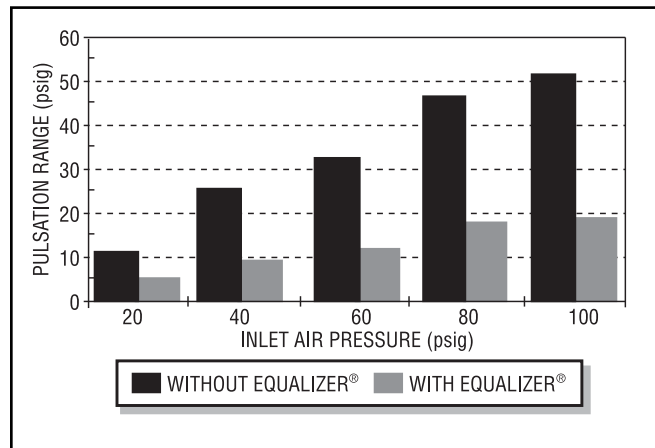

2" (51mm) pumps/SD2

The above chart reflects the discharge pressure variation of a Wilden model 2" (51mm) Polypropylene pump with rubber elastomers compared to the same 2" (51mm) with a model SD2 Equalizer® installed.

SD $\frac{1}{2}$ DIMENSIONAL DRAWING

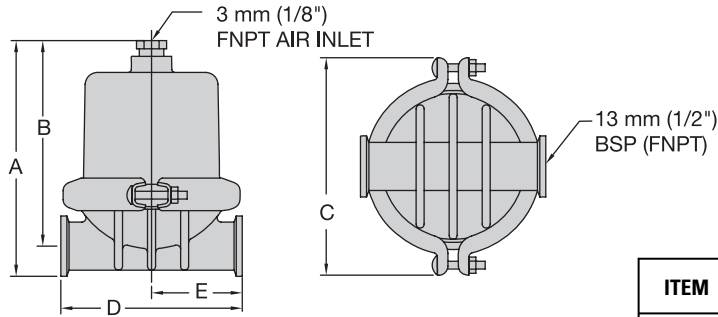

SD $\frac{1}{2}$ ($\frac{1}{2}$ " INLET/DISCHARGE)

MATERIAL	SHP. WT.	MATERIAL	SHP. WT.
Aluminum	3.1 lbs.	PVDF	2.9 lbs.
316 Stainless Steel	4.8 lbs.	Teflon® PFA*	3.7 lbs.
Polypropylene	2.4 lbs.		

ITEM	METAL		PLASTIC		TEFLON® PTFE	
	mm	(INCH)	mm	(INCH)	mm	(INCH)
A	180	(7.1)	180	(7.1)	175	(6.9)
B	160	(6.3)	157	(6.2)	157	(6.2)
C	175	(6.3)	175	(6.9)	175	(6.9)
D	117	(4.6)	142	(5.6)	145	(5.7)
E	69	(2.7)	71	(2.8)	71	(2.8)

*All Teflon® Equalizers® are assembled in a Class 10,000 Clean Room.

SD1 DIMENSIONAL DRAWING

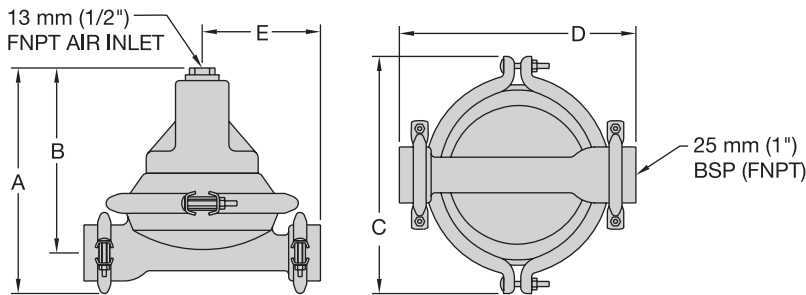

SD1 (1" INLET/DISCHARGE)

MATERIAL	SHP. WT.	MATERIAL	SHP. WT.
Aluminum	18 lbs.	PVDF	19 lbs.
316 Stainless Steel	24 lbs.	Teflon® PFA*	21 lbs.
Polypropylene	18 lbs.		

ITEM	METAL		PLASTIC	
	mm	(INCH)	mm	(INCH)
A	279	(11.0)	292	(11.5)
B	229	(9.0)	236	(9.3)
C	290	(11.4)	290	(11.4)
D	295	(11.6)	384	(15.1)
E	147	(5.8)	191	(7.5)

*All Teflon® Equalizers® are assembled in a Class 10,000 Clean Room.

SD2 DIMENSIONAL DRAWING

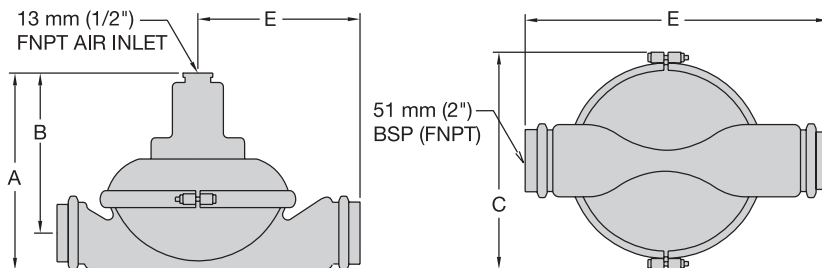

SD2 (2" INLET/DISCHARGE)

MATERIAL	SHP. WT.	MATERIAL	SHP. WT.
Aluminum	27 lbs.	Polypropylene	28 lbs.
Cast Iron	47 lbs.	PVDF	34 lbs.
316 Stainless Steel	44 lbs.		

ITEM	METAL		PLASTIC	
	mm	(INCH)	mm	(INCH)
A	305	(12.0)	343	(13.5)
B	249	(9.8)	267	(10.5)
C	351	(13.8)	351	(13.8)
D	455	(17.9)	493	(19.4)
E	244	(9.6)	274	(10.8)

SD2 BOLTED DIMENSIONAL DRAWING

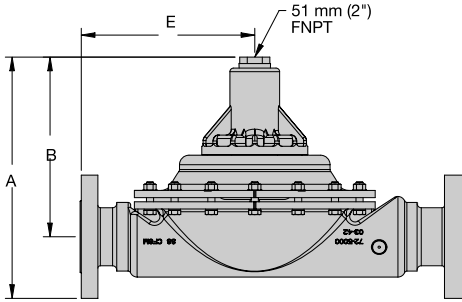

ITEM	METRIC (mm)	STANDARD (inch)
A	323	12.7
B	241	9.5
C	325	12.8
D	513	20.2
E	234	9.2
	DIN (mm)	ANSI (inch)
F	125 DIA	4.8 DIA
G	165 DIA	6.5 DIA
H	18 DIA	.8 DIA

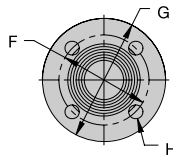
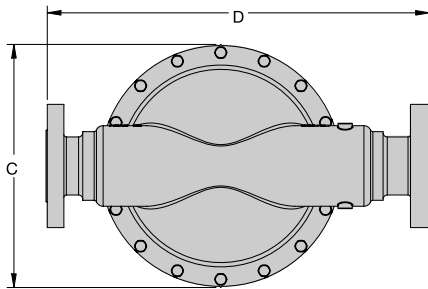

SD2 (2" INLET/DISCHARGE)

MATERIAL	SHP. WT.
316 Stainless Steel	81 lbs.
Hastelloy®	86 lbs.

SD3 SANIFLO™ DIMENSIONAL DRAWING

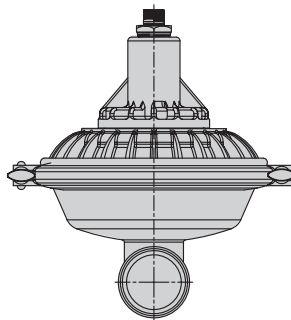
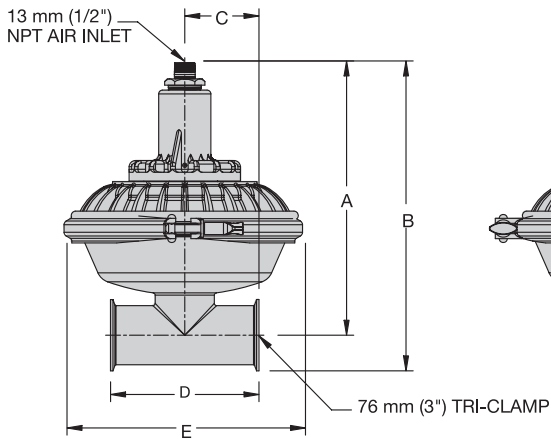

ITEM	METRIC (mm)	STANDARD (inch)
A	353	13.9
B	399	15.7
C	94	3.7
D	191	7.5
E	305	12.0
F	368	14.5

SD3 (3" INLET/DISCHARGE)

MATERIAL	SHP. WT.
316 Stainless Steel	65 lbs.

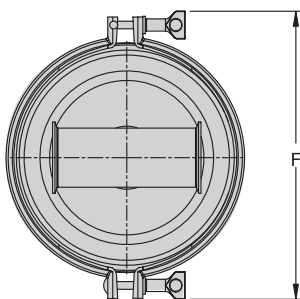

INSTALLATION

The model SD $\frac{1}{2}$ has a $\frac{1}{2}$ " inlet/discharge. The model SD1 has a 1" inlet/discharge. The model SD2 has a 2" inlet/discharge. The Equalizer[®] can be installed in either direction. A variety of materials are available to satisfy temperature, chemical compatibility, abrasion and flex concerns. The Equalizer[®] installed on the discharge side of the pump minimizes pulsation and protects in-line equipment. It can also be connected on the suction side to prevent water hammer associated with a positive inlet condition.

The model SD $\frac{1}{2}$ is engineered for use with Wilden $\frac{1}{4}$ (6mm) and $\frac{1}{2}$ (13mm) pumps. The model SD1 is engineered for use with Wilden 1" (25mm) pumps. It can also be used with the $1\frac{1}{2}$ (38mm) in applications where the discharge pressure is less than 50 psi. The model SD2 is

engineered for use with Wilden $1\frac{1}{2}$ (38mm) and 2" (51mm) pumps.

Install the Equalizer[®] as shown below. The use of flexible connections and a Filter, Regulator, Lubricator (FRL) will extend parts life on the SD1 and SD2. Lubrication is not needed for the SD $\frac{1}{2}$. Shut off valves on the suction side of pump and the discharge side of Equalizer[®] will enable maintenance personnel to safely service the equipment. To maximize effectiveness install the Equalizer[®] as close as possible to the discharge of the pump. **It is important to support the pipe immediately downstream from the Equalizer[®].**

Use a tee connector on the pump air supply line and connect the line to the Equalizer[®] regulator body. This tee connector should be installed after the FRL. The Equalizer[®] consumes very little air, therefore, a $\frac{1}{4}$ " hose is

SUGGESTED INSTALLATION

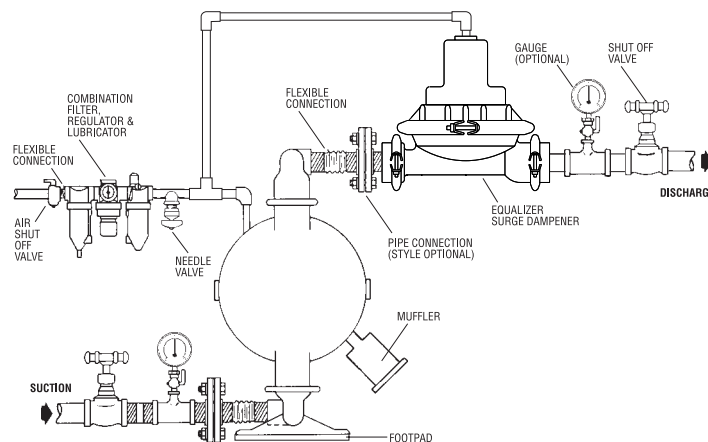

TROUBLESHOOTING

When there is a significant drop in the fluid discharge pressure, there will be a noticeable release of air through the small bleed hole in the air regulator body. This is how the Equalizer[®] automatically adjusts itself for optimal suppression. This is a good way of verifying proper operation of the unit. If there is a continuous discharge of air out this hole during steady fluid discharge pressure, the Equalizer[®] is not functioning properly and should be inspected. The SD1 and SD2 air regulator body houses three O-rings which may need to be replaced. A few drops of oil in the top of the regulator every 200 hours of operation will significantly extend the life of these O-rings. The SD $\frac{1}{2}$ utiliz-

es 3 slipper seals with back-up O-rings which allow lubrication-free operation.

Fluid leakage around the clamp band area is normally stopped by tightening the clamp band bolts. If leakage continues, unit should be disassembled and inspected.

Air leakage at the bottom of the SD1 and SD2 air regulator body normally requires the tightening of the three screws located in the air chamber. If leakage continues, the gasket between the air regulator body and air chamber should be replaced.

If air bubbles in fluid discharge line are present, check for diaphragm rupture and tightness of clamp bands.

DIRECTIONS FOR DISASSEMBLY/ASSEMBLY (SD $\frac{1}{2}$)



To expedite parts ordering, please find an exploded view of the Equalizer® models at the back of this manual. If you have any questions, please call your local authorized Wilden distributor, or call Wilden Pump & Engineering Co. at (909) 422-1730.

TOOLS REQUIRED

SD $\frac{1}{2}$ (1/2" INLET/DISCHARGE)

7/16" Open-Ended Wrench
7/8" Open-Ended Wrench
O-ring Pick

CAUTION: Before any maintenance or repair is attempted, the compressed air line to the Equalizer® and the pump should be disconnected and all air pressure allowed to bleed from these units. Disconnect all intake, discharge, and air lines. Always wear safety glasses and proper clothing for added protection.

PLEASE READ ALL DIRECTIONS BEFORE STARTING DISASSEMBLY.

STEP 1



Figure 1

Loosen clamp band with 7/16" open-ended wrench (Figure 1).

STEP 2



Figure 2

Remove liquid chambers, inspect for damage, and set aside (Figure 2).

STEP 3



Figure 3

Pull diaphragm assembly (shaft, diaphragm[s], inner and outer piston) away from air regulator body. Loosen outer piston with a 7/8" wrench or adjustable wrench and inspect diaphragm and shaft for abrasion or chemical attack. Soft jaws in vise may need to be used if outer piston does not unfasten easily (*Figure 3*).

STEP 4



Figure 4

Air regulator slipper seals and back-up O-rings need to be inspected. If worn or chemically attacked they must be removed with an O-ring pick and replaced (*Figure 4*). Please refer to exploded view for part numbers.

ASSEMBLY

Prior to assembling the Equalizer®, please read this page first. Then refer to the disassembly instructions for photos and placement of parts.

Rubber Diaphragm

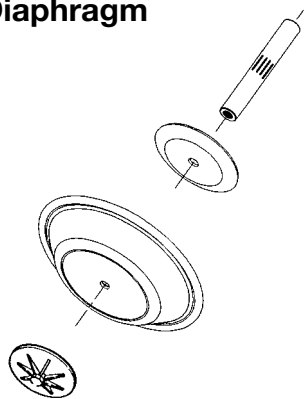

There are two types of diaphragm configurations available for the SD½: 1) Rubber diaphragm, and 2) Teflon® primary diaphragm with back-up diaphragm. Observe the "This side out" marking on the convex side of the dia-

Teflon® Diaphragm

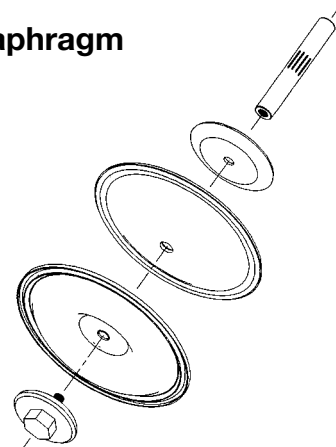

phragm. Install the inner piston, diaphragm(s), outer piston plate and stop on shaft. Teflon®-fitted Equalizers require Teflon® gasket material tape to properly seal diaphragm bead area. See page 14 for instructions.

DIRECTIONS FOR DISASSEMBLY/ASSEMBLY (SD1 & SD2)

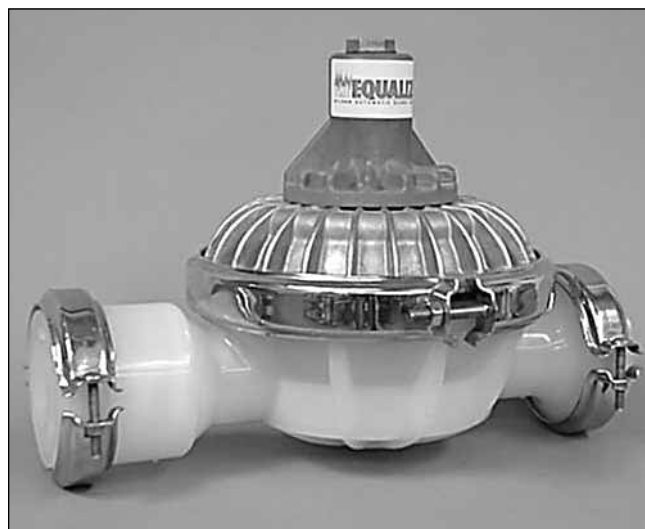

TOOLS REQUIRED

SD1 (1" INLET)

- 3/4" Socket
- 1/2" Socket
- 3/16" Allen Wrench
- O-ring Pick
- Adjustable Wrench
- Pipe Wrench
- 2 Pry Bars (screwdrivers)

SD2 (2" INLET)

- 3/4" Socket
- 1/2" Socket
- 11/16" Socket
- 7/32" Allen Wrench
- O-ring Pick
- Adjustable Wrench
- Pipe Wrench
- 2 Pry Bars (screwdrivers)

CAUTION: Before any maintenance or repair is attempted, the compressed air line to the Equalizer® and the pump should be disconnected and all air pressure allowed to bleed from these units. Disconnect all intake, discharge, and air lines. Always wear safety glasses and proper clothing for added protection.

PLEASE READ ALL DIRECTIONS BEFORE STARTING DISASSEMBLY.

The instruction photos depict the SD2 polypropylene Equalizer®. The disassembly/assembly instructions are similar for the SD1 except where noted. To expedite parts ordering, please find an exploded view of the Equalizer® models at the back of this manual. If you have any questions, please call your local authorized Wilden distributor.

STEP 1

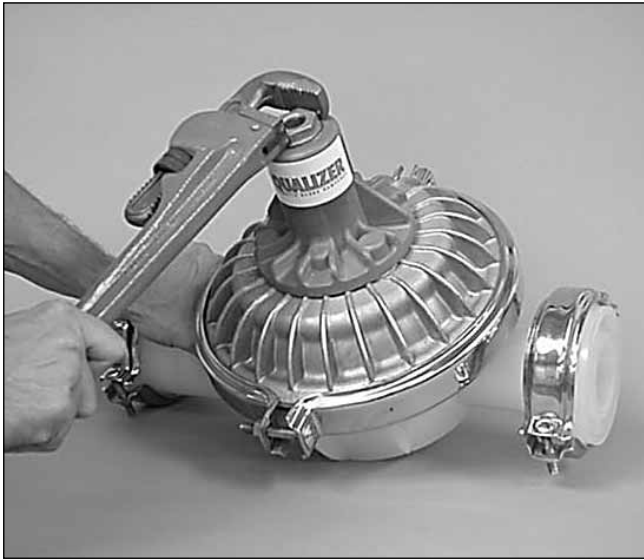

Figure 1

Remove reducer bushing at top of regulator. (Use pipe wrench.)

STEP 2



Figure 2

Remove large clamp band.

STEP 3



Figure 3

Set liquid chamber aside.



Figure 4

Loosen shaft assembly by using adjustable wrench on outer piston and 3/4" socket on shaft bolt inside air regulator body. Turn counter clockwise. One of two scenarios will occur: outer piston will loosen from shaft, or the shaft bolt will loosen from shaft.

STEP 3 (Cont'd.)



Figure 5

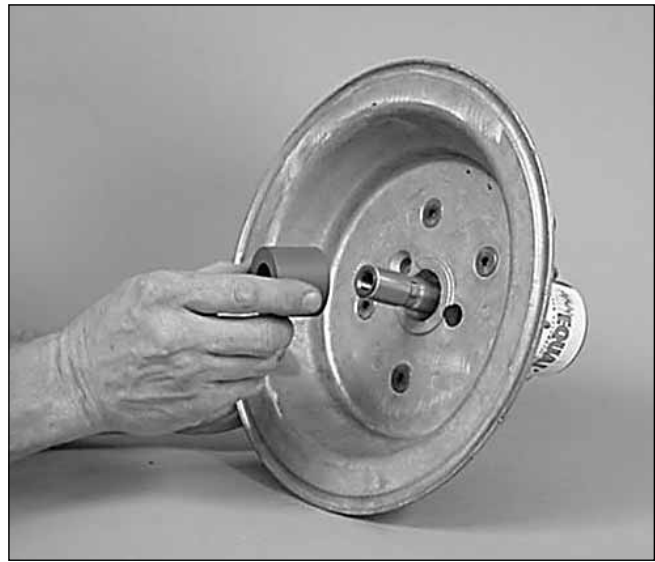

Figure 6

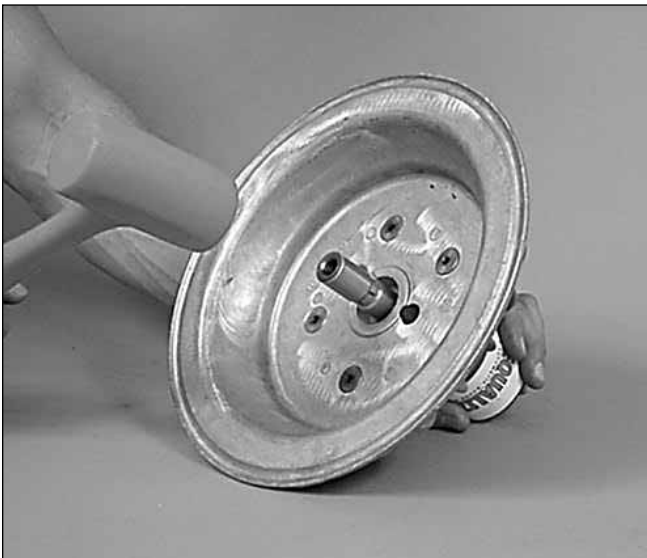

Figure 5



Figure 6

If outer piston loosens, remove outer piston, diaphragm, inner piston, and stop. Then knock shaft through regulator with soft mallet. (See *Figure 7.*) Remove shaft bolt and washer from shaft. Note: Protect the shaft from damage by using wood blocks or soft jaws in vise. (See *Figure 8.*)

STEP 3 (Cont'd.)



Figure 9

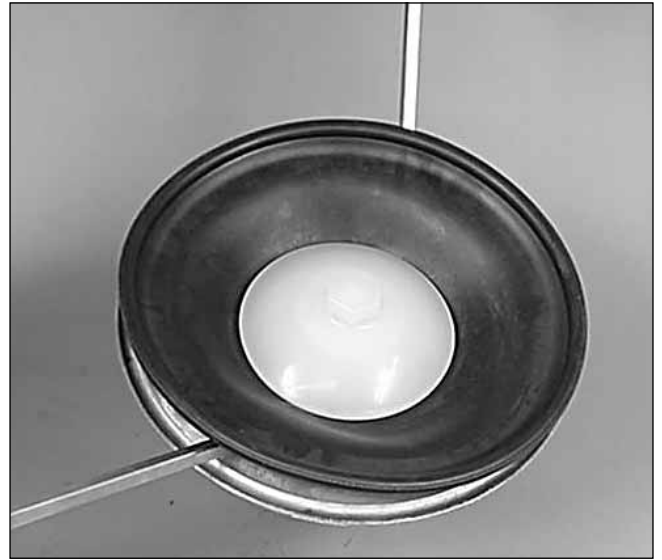

Figure 10



Figure 11

If shaft bolt loosens, remove bolt and washer. (See *Figure 9.*) Turn Equalizer® upside down and use two pry bars between inner piston and air chamber to pull shaft assembly from regulator. (See *Figure 10.*) Remove Stop. Disassemble shaft assembly by loosening outer piston. Note: Protect the shaft from damage by using wood blocks or soft jaws in vise. (See *Figure 11.*)

STEP 4

Inspect shaft for nicks or abrasion. Small nicks can usually be dressed out. If shaft is chemically attacked or nicks are hindering operation, shaft should be replaced.

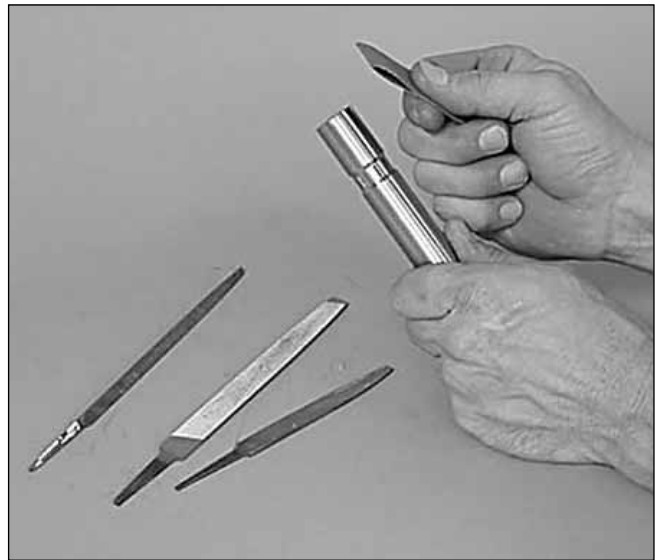

Figure 12

STEP 5



Figure 13

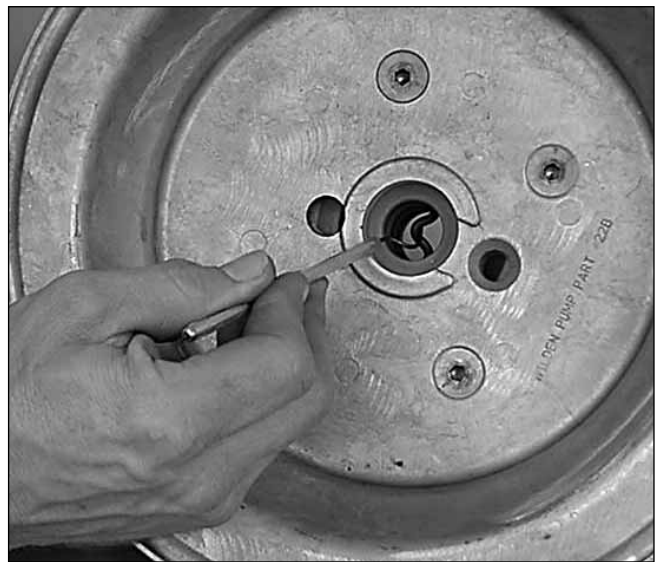

Figure 14

Replace Glyd™-rings in air regulator body. This is most easily accomplished by using a tool called an O-ring pick, available through most industrial supply companies. The air regulator body has 5 grooves cut into the inside diameter. There are three Glyd™-rings installed in the 1, 3, 5 positions. It is important that these Glyd™-rings be installed in the correct grooves so that the Equalizer® functions properly.

STEP 6



Figure 15

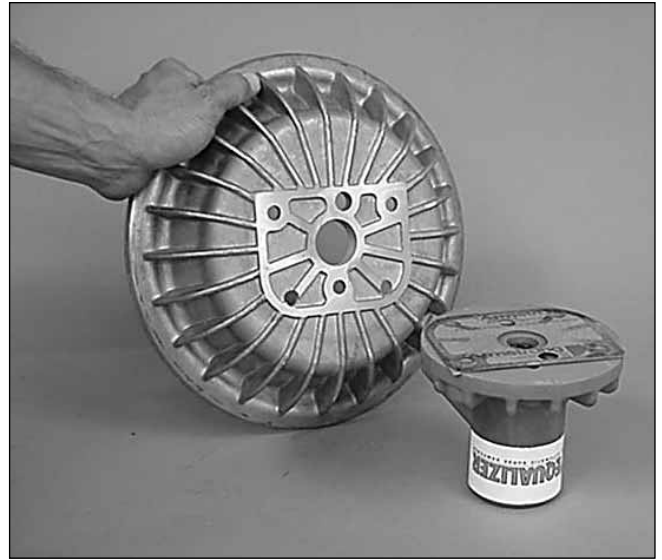

Figure 16

Disassembly of the air chamber from the regulator is needed only in the event of air leakage. Leakage is usually stopped by tightening the allen head bolts. (See *Figure 15.*) If leakage persists, remove air chamber and replace gasket.

STEP 7



Figure 17



Figure 18

Disassembly of the Surge ends/small clamp band is needed only in the event of leakage. Leakage is usually stopped by tightening the small band bolt. (See *Figure 19.*) If leakage persists, remove surge ends and replace O-rings.

ASSEMBLY

Prior to assembling the Equalizer®, please read this page first. Then refer to the disassembly instructions for photos and placement of parts.

Rubber Diaphragm

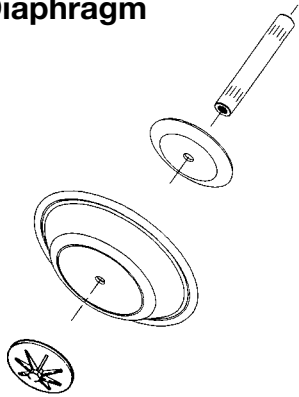

Teflon® Diaphragm

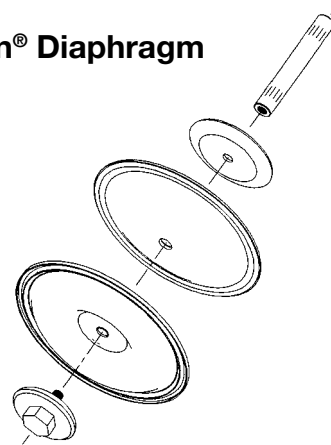

There are two types of diaphragm configurations available for the SD1 and SD2: 1) Rubber diaphragm, and 2) Teflon® primary diaphragm with back-up diaphragm. Observe the “This side out” marking on the convex

side of the diaphragm. Install the inner piston, diaphragm(s), outer piston plate and stop on shaft. Lubricate the air regulator body Glyd™-rings with a 5 wt. arctic grade oil prior to inserting the shaft through the air regulator body.

EQUALIZERS WITH TEFLON® DIAPHRAGMS ONLY

All Teflon® fitted Equalizers require expanded Teflon® gasket material with the exception of all aluminum Equalizers and stainless steel SD1 Equalizers. This type of Teflon® is very strong, but soft. Its use assures a positive

seal between the Teflon® diaphragm outer bead and its corresponding groove in the liquid chamber. This gasket material should be replaced each time the Equalizer® is disassembled.

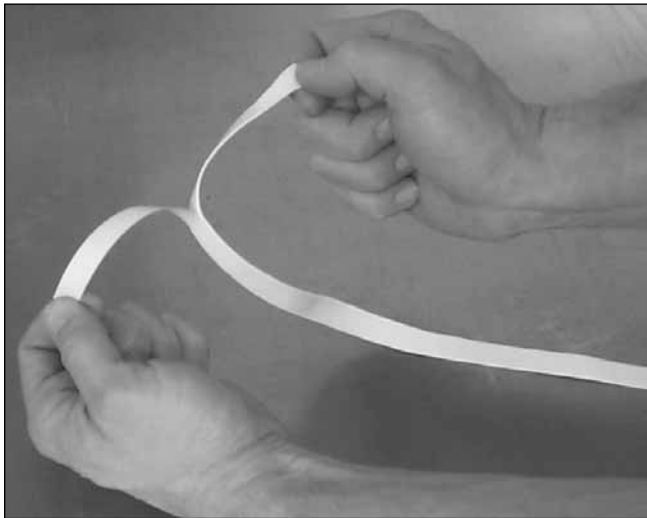

Select a strip of ½”-wide material and carefully remove the covering from the adhesive strip. Ensure that the adhesive strip remains attached to the gasket material. Starting at any point, place the gasket strip in the center of

the diaphragm bead groove on the diaphragm and press lightly on the gasket to ensure that adhesive holds it in place during assembly. The ends of the gasket should overlap approximately ½”. The part number for the gasket kit is 08-9502-99.

WILDEN PUMP DESIGNATION SYSTEM

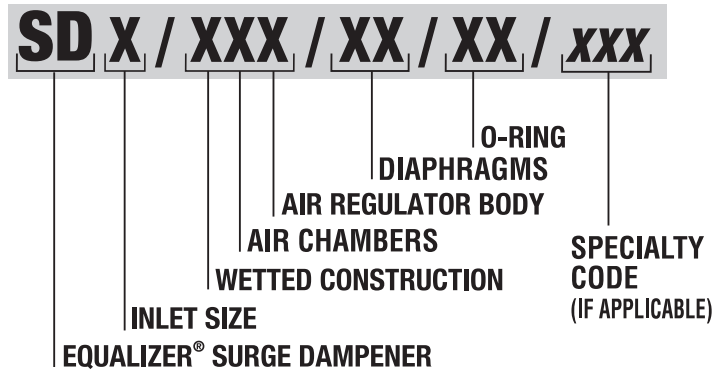

EQUALIZER® SURGE DAMPENER MATERIAL CODES

INLET SIZE

- 1/2 = 1/2 INCH
- 1 = 1 INCH
- 2 = 2 INCH
- 3 = 3 INCH

WETTED CONSTRUCTION

- A = ALUMINUM (SD $\frac{1}{2}$, SD1 & SD2)
- G = CARBON-FILLED ACETAL (SD $\frac{1}{2}$)
- K = PVDF (SD $\frac{1}{2}$, SD1 & SD2)
- P = POLYPROPYLENE (SD $\frac{1}{2}$, SD1 & SD2)
- S = STAINLESS STEEL
- T = TEFLON® PTFE (SD $\frac{1}{2}$)
- T = TEFLON® PFA (SD1 ONLY)
- W = CAST IRON (SD1 AND SD2)

AIR CHAMBER

- A = ALUMINUM (SD2)
- C = TEFLON® COATED (SD1 & SD2)
- G = CARBON-FILLED ACETAL (SD $\frac{1}{2}$)
- M = MILD STEEL (SD1)
- P = POLYPROPYLENE (SD $\frac{1}{2}$)
- S = STAINLESS STEEL (SD2 & SD3)
- W = CAST IRON (SD2)

AIR REGULATOR BODY

- G = CARBON-FILLED ACETAL (SD $\frac{1}{2}$ ONLY)
- P = POLYPROPYLENE

DIAPHRAGM

- BN = BUNA-N (SD $\frac{1}{2}$, SD1 & SD2)
- FB = FDA BUNA-N (SD3 ONLY)
- FE = FDA NORDEL (EPDM) (SD3 ONLY)
- FG = SANIFLEX™ (SD $\frac{1}{2}$, SD1 & SD3)
- FW = FDA WIL-FLEX™ (SD3 ONLY)
- ND = NORDEL® (SD $\frac{1}{2}$, SD1 & SD2)
- NE = NEOPRENE (SD1 & SD2)
- TF = TEFLON® TFE
- TS = TEFLON® TFE W/SANIFLEX™ BACKUP
- VT = VITON® (SD $\frac{1}{2}$, SD1 & SD2)
- WF = WIL-FLEX™ (SD $\frac{1}{2}$ & SD1)

O-RINGS

- BN = BUNA-N
- TF = TEFLON®
- TV = TEFLON® ENCAP. VITON®

SPECIALTY CODES

- 003 = ALLOY FITTED (SD1 & SD2)
- 014 = BSP
- 015 = ALLOY FITTED, BSP (SD1 & SD2)
- 040 = BOLTED, ANSI FLANGE (SD2 ONLY)
- 041 = BOLTED, DIN FLANGE (SD2 ONLY)
- 072 = SANIFLO™ USDA (SD3 ONLY)
- 315 = W/TEFLON® COATED HARDWARE/BSP
- 502 = W/TEFLON® COATED HARDWARE

Nordel and Viton are registered trademarks of DuPont Dow Elastomers.
Teflon is a registered trademark of DuPont.

NOTES:

EXPLODED VIEWS

SD $\frac{1}{2}$ EQUALIZER®
SD1, SD2 AND SD3 EQUALIZER®
ELASTOMER OPTIONS
TORQUE SPECIFICATIONS

THE EQUALIZER®

(SD $\frac{1}{2}$)
Exploded View

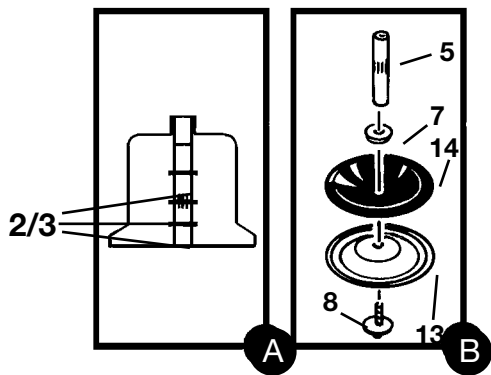
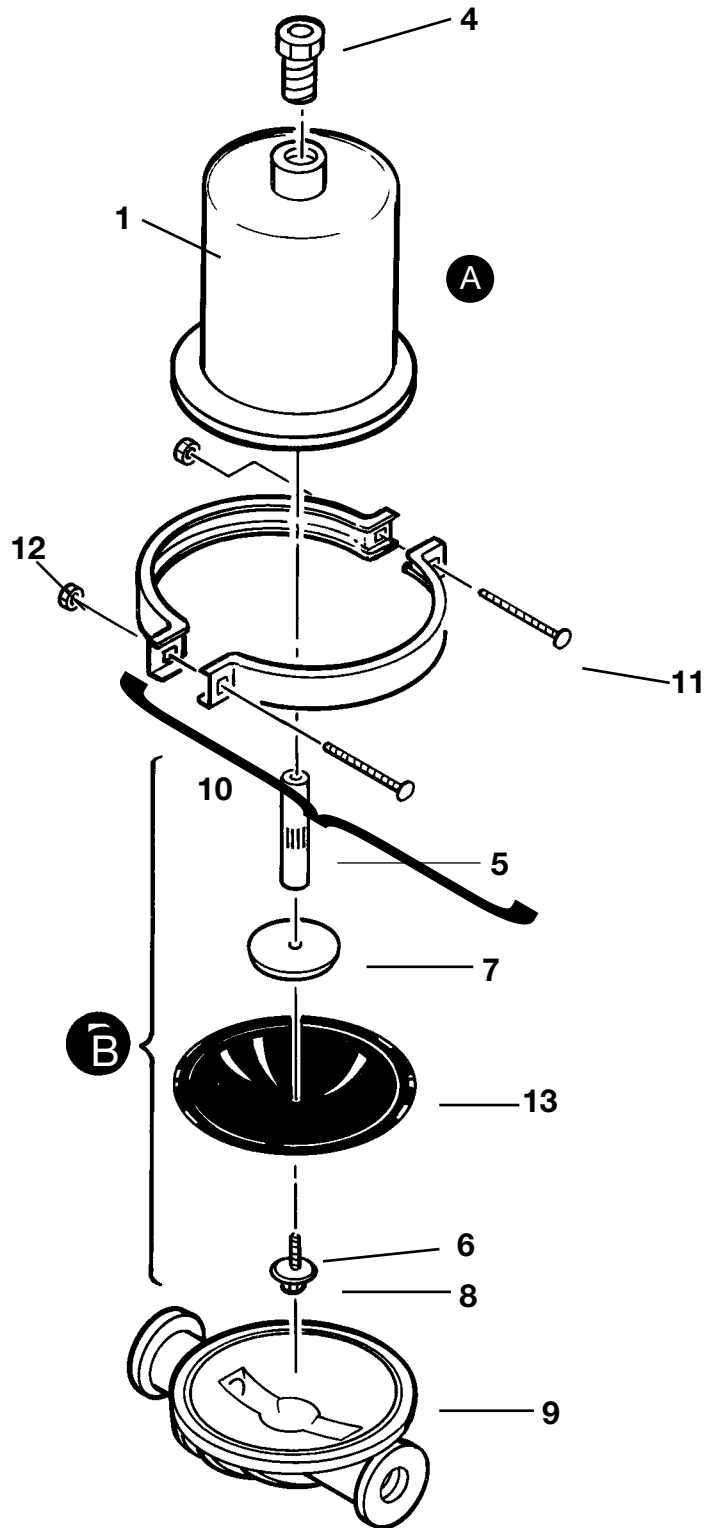

SD½ EQUALIZER®

			POLYPROPYLENE	PVDF	CARBON-FILLED ACETAL	TEFLON® PTFE
ITEM	PART DESCRIPTION	QTY.	SD1/2/PPP	SD1/2/KPP	SD1/2/GGG	SD1/2/TPP
1	Air Regulator Body ¹	1	72-8500-20	72-8500-20	72-8500-16	72-8500-20
2	Slipper Seal	3	01-3210-55-200	01-3210-55-200	01-3210-55-200	01-3210-55-200
3	Back-Up O-Ring	3	01-2390-52	01-2390-52	01-2390-52	01-2390-52
4	Reducer Bushing	1	72-6950-07	72-6950-07	72-6950-07	72-6950-07
5	Straight Shaft	1	01-3800-03-07	01-3800-03-07	01-3800-03-07	01-3800-03-07
6	S.S. Threaded Stud	1	NA	NA	NA	NA
7	Inner Piston	1	01-3710-01	01-3710-01	01-3710-01	01-3710-01
8	Outer Piston	1	01-4570-20-500	01-4570-21-500	01-4570-16	01-4570-22-500
9	Liquid Chamber ²	1	72-5000-20	72-5000-21	72-5000-16	72-5000-55
10	Clamp Band Assembly	1	01-7300-03	01-7300-03	01-7300-03	01-7300-03
11	Carriage Bolt, 1/4-20 x 2	2	01-6070-03	01-6070-03	01-6070-03	01-6070-03
12	Nut, HEX (1/4-20)	2	04-6400-03	04-6400-03	04-6400-03	04-6400-03
13	Primary Diaphragm⁵	1	*	*	*	*
14	Back-Up Diaphragm⁴	1	01-1060-51	01-1060-51	01-1060-51	01-1060-51
	Grounding Strap (Not Shown)	1	N/A	N/A	00-8300-99	N/A

¹Air regulator body includes slipper seals and back-up O-rings.

²Liquid chamber is available with BSP threads. The additional digits "14" added to the end of the part number designated BSP threads.

⁴Back-up diaphragm is only utilized with Teflon® primary diaphragm.

⁵Teflon® Gasket Kit, P/N 01-9500-99, required.

*Refer to page 30 for elastomer options.

All bold face items are primary wear parts.

			ALUMINUM	STAINLESS STEEL
ITEM	PART DESCRIPTION	QTY.	SD1/2/APP	SD1/2/SPP
1	Air Regulator Body ¹	1	72-8500-20	72-8500-20
2	Slipper Seal	3	01-3210-55-200	01-3210-55-200
3	Back-Up O-Ring	3	01-2390-52	01-2390-52
4	Reducer Bushing	1	72-6950-07	72-6950-07
5	Straight Shaft	1	01-3800-03-07	01-3800-03-07
6	S.S. Threaded Stud	1	NA	01-6150-03
7	Inner Piston	1	01-3710-01	01-3710-01
8	Outer Piston	1	01-4570-01	01-4570-03
9	Liquid Chamber ²	1	72-5000-01	72-5000-03
10	Clamp Band Assembly	1	01-7300-03	01-7300-03
11	Carriage Bolt, 1/4-20 x 2	2	01-6070-03	01-6070-03
12	Nut, HEX (1/4-20)	2	04-6400-03	04-6400-03
13	Primary Diaphragm³	1	*	*
14	Back-Up Diaphragm⁴	1	01-1060-51	01-1060-51

¹Air regulator body includes slipper seals and back-up O-rings.

²Liquid chamber is available with BSP threads. The additional digits "14" added to the end of the part number designated BSP threads.

³Refer to page 30 for elastomer options.

⁴Back-up diaphragm is only utilized with Teflon® primary diaphragm.

All bold face items are primary wear parts.

THE EQUALIZER® (SD1 and SD2) Exploded View

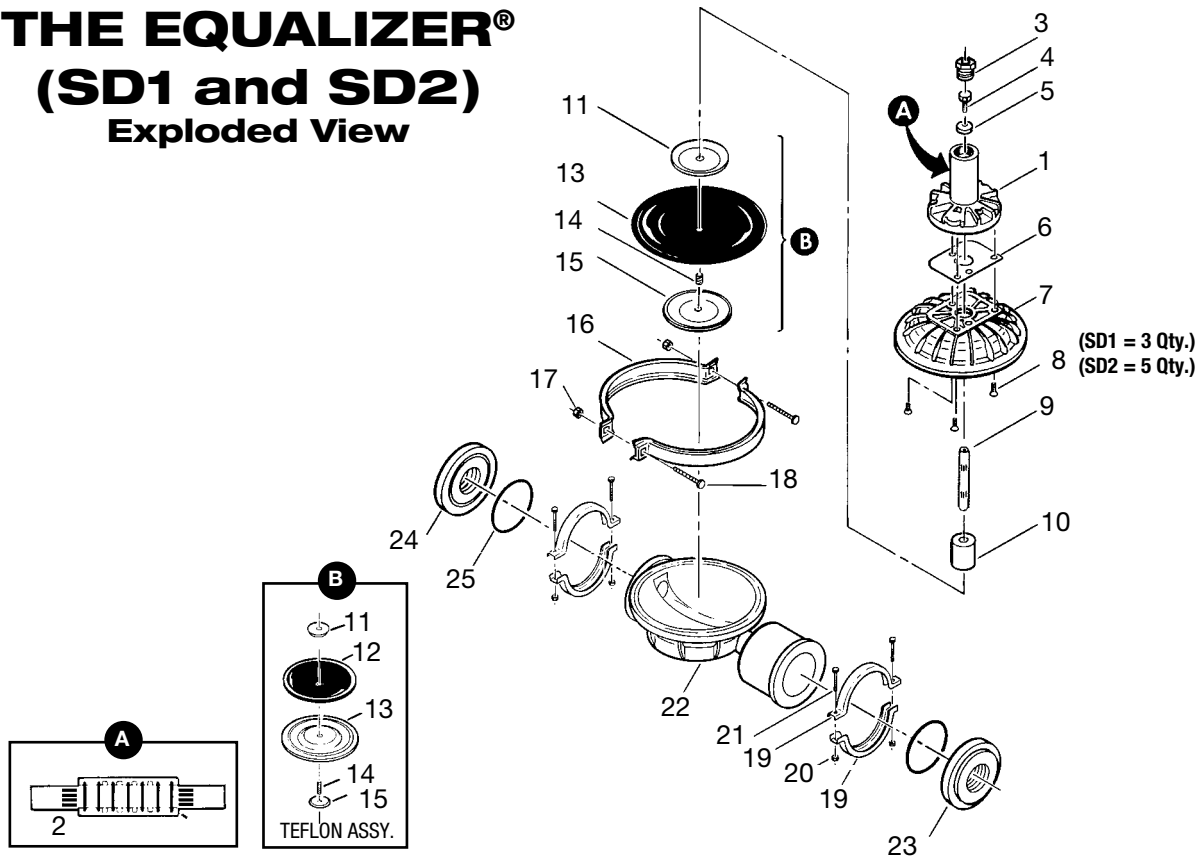

THE EQUALIZER® SD2 Bolted Exploded View

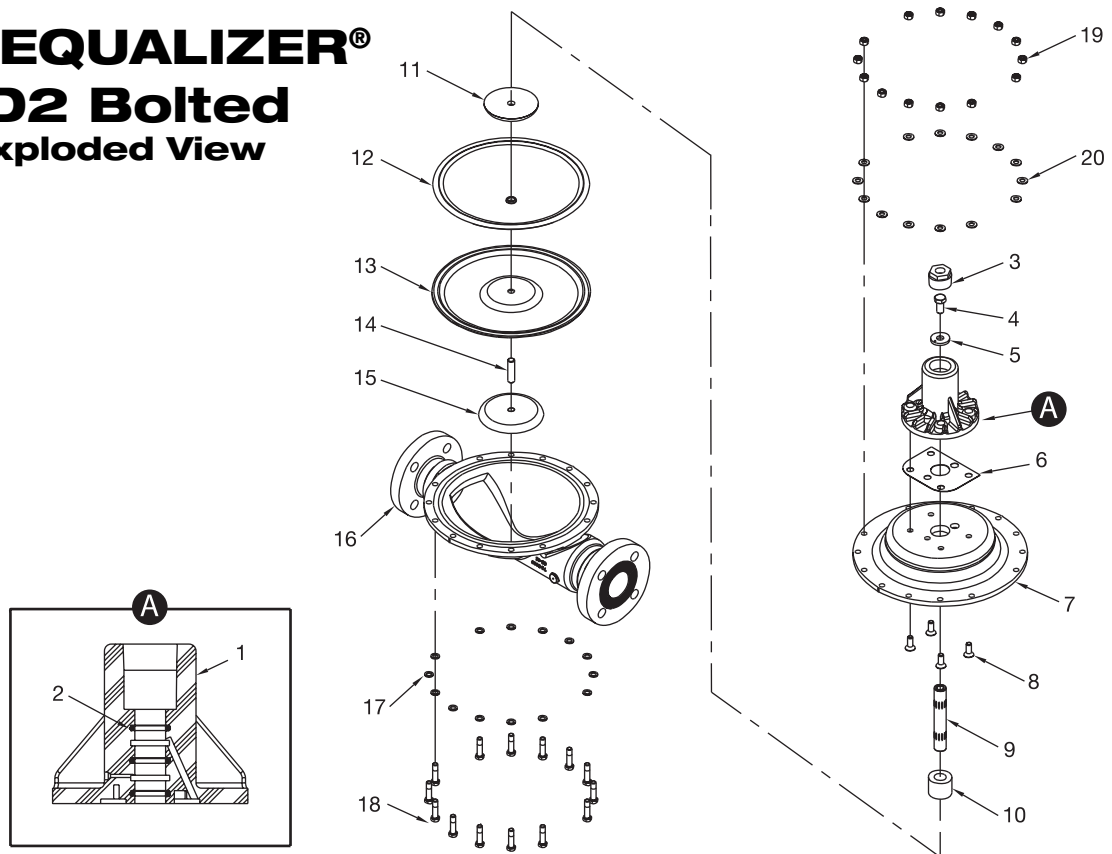

SD1 EQUALIZER® Aluminum Construction

ITEM	PART DESCRIPTION	QTY.	SD1-AMP	SD1-AMP-TF
1	Air Regulator Body ¹	1	70-8500-20	70-8500-20
2	Glyd™ Ring	3	08-3210-55-225	08-3210-55-225
3	Reducer Bushing 1 1/4 x 1/2 NPT	1	70-6950-08	70-6950-08
4	Shaft Bolt 1/2-20 x 1	1	04-6090-08	04-6090-08
5	Flat Washer	1	70-6790-08	70-6790-08
6	Center Block Gasket	1	04-3520-52	04-3520-52
7	Air Chamber	1	04-3650-08	04-3650-08
8	Socket Head Cap Screw 1/4-20 x 7/8	3	70-6250-03	70-6250-03
9	Shaft	1	04-3820-03-07	04-3820-03-07
10	Stop	1	70-8800-17	70-8800-17
11	Inner Piston	1	04-3700-08	70-3750-01
12	Back Up Diaphragm	1	N/R	04-1060-51
13	Diaphragm	1	*	04-1010-55
14	Shaft Stud 1/2-20 x 1 1/2 All Thd	1	N/R	04-6150-08
15	Outer Piston	1	04-4552-01	04-4600-01
16	Large Clamp Band Assembly	1	04-7300-08	04-7300-03
17	Hex Nut 5/16-18	2	04-6420-08	08-6400-03
18	Carriage Bolt 5/16-18 x 2 1/2	2	04-6070-08	04-6070-03
19	Small Clamp Band Assembly	2	04-7100-08	04-7100-03
20	Hex Nut 1/4-20	4	04-6400-08	04-6400-03
21	Carriage Bolt 1/4-20 x 2	4	04-6050-08	01-6070-03
22	Liquid Chamber	1	04-5000-01	04-5000-01
23	Surge End	1	70-8600-01	70-8600-01
24	Surge End	1	70-8600-01	70-8600-01
25	Surge End O-Ring	2	*	70-1280-55

¹Air Regulator Body includes qty. 3 shaft Glyd™-rings.
All bold face items are primary wear parts.

SD1 EQUALIZER® Stainless Steel Construction

ITEM	PART DESCRIPTION	QTY.	SD1-SMP	SD1-SMP-TF
1	Air Regulator Body ¹	1	70-8500-20	70-8500-20
2	Glyd™ Ring	3	08-3210-55-225	08-3210-55-225
3	Reducer Bushing 1 1/4 x 1/2 NPT	1	70-6950-08	70-6950-08
4	Shaft Bolt 1/2-20 x 1	1	04-6090-08	04-6090-08
5	Flat Washer	1	70-6790-08	70-6790-08
6	Center Block Gasket	1	04-3520-52	04-3520-52
7	Air Chamber	1	04-3650-08	04-3650-08
8	Socket Head Cap Screw 1/4-20 x 7/8	3	70-6250-03	70-6250-03
9	Shaft	1	04-3820-03-07	04-3820-03-07
10	Stop	1	70-8800-17	70-8800-17
11	Inner Piston	1	04-3700-08	70-3750-01
12	Back Up Diaphragm	1	N/R	04-1060-51
13	Diaphragm	1	*	04-1010-55
14	Shaft Stud 1/2-20 x 1 1/2 All Thd	1	04-6150-08	04-6150-08
15	Outer Piston	1	04-4550-03	04-4600-03
16	Large Clamp Band Assembly	1	04-7300-03	04-7300-03
17	Hex Nut 5/16-18	2	08-6400-03	08-6400-03
18	Carriage Bolt 5/16-18 x 2 1/2	2	04-6070-03	04-6070-03
19	Small Clamp Band Assembly	2	04-7100-03	04-7100-03
20	Hex Nut 1/4-20	4	04-6400-03	04-6400-03
21	Carriage Bolt 1/4-20 x 2	4	01-6070-03	01-6070-03
22	Liquid Chamber	1	04-5000-03	04-5000-03
23	Surge End	1	70-8600-03	70-8600-03
24	Surge End	1	70-8600-03	70-8600-03
25	Surge End O-Ring	2	*	70-1280-55

¹Air Regulator Body includes qty. 3 shaft Glyd™-rings.
*Elastomer options listed on page 30.

All bold face items are primary wear parts.

SD1 EQUALIZER® Polypropylene Construction

ITEM	PART DESCRIPTION	QTY.	POLY PMP	POLY PMP-TF	POLY PCP-502	POLY PCP-TF-502
1	Air Regulator Body ¹	1	70-8500-20	70-8500-20	70-8500-20	70-8500-20
2	Glyd™ Ring	3	08-3210-55-225	08-3210-55-225	08-3210-55-225	08-3210-55-225
3	Reducer Bushing 1 1/4 x 1/2 NPT	1	70-6950-08	70-6950-08	70-6950-05	70-6950-05
4	Shaft Bolt 1/2-20 x 1	1	04-6090-08	04-6090-08	04-6090-08	04-6090-08
5	Flat Washer	1	70-6790-08	70-6790-08	70-6790-08	70-6790-08
6	Center Block Gasket	1	04-3520-52	04-3520-52	04-3520-52	04-3520-52
7	Air Chamber	1	04-3650-08	04-3650-08	04-3650-05	04-3650-05
8	Socket Head Cap Screw 1/4-20 x 7/8	3	70-6250-03	70-6250-03	70-6250-03	70-6250-03
9	Shaft	1	04-3820-03-07	04-3820-03-07	04-3820-03-07	04-3820-03-07
10	Stop	1	70-8800-17	70-8800-17	70-8800-17	70-8800-17
11	Inner Piston	1	04-3700-08	04-3750-01	04-3700-08	04-3750-01
12	Back Up Diaphragm	1	N/R	04-1060-51	N/R	04-1060-51
13	Diaphragm	1	*	04-1010-55	*	04-1010-55
14	Shaft Stud 1/2-20 x 1 1/2 All Thd	1	N/R	N/R	N/R	N/R
15	Outer Piston	1	04-4550-20-500	04-4600-20-500	04-4550-20-500	04-4600-20-500
16	Large Clamp Band Assembly	1	04-7330-03	04-7330-03	04-7330-05	04-7330-05
17	Hex Nut 5/16-18	2	08-6400-03	08-6400-03	08-6400-05	08-6400-05
18	Carriage Bolt 5/16-18 x 2 1/2	2	04-6070-03	04-6070-03	04-6070-05	04-6070-05
19	Small Clamp Band Assembly	2	04-7100-03-500	04-7100-03-500	04-7100-05-500	04-7100-05-500
20	Hex Nut 5/16-18	4	08-6400-03	08-6400-03	08-6400-05	08-6400-05
21	Carriage Bolt 5/16-18 x 2	4	08-6050-03-500	08-6050-03-500	08-6050-05-500	08-6050-05-500
22	Liquid Chamber	1	04-5000-20	04-5000-20	04-5000-20	04-5000-20
23	Surge End	1	70-8600-20	70-8600-201	70-8600-20	70-8600-20
24	Surge End	1	70-8600-20	70-8600-20	70-8600-20	70-8600-20
25	Surge End O-Ring	2	*	70-1270-60	*	70-1270-60

¹Air Regulator Body includes qty. 3 shaft Glyd™-rings. **All bold face items are primary wear parts.**

²Teflon® Gasket Kit, P/N 04-9500-99, required.

SD1 EQUALIZER® PVDF Construction

ITEM	PART DESCRIPTION	QTY.	PVDF KMP	PVDF KMP-TF	PVDF KCP-502	PVDF KCP-TF-502
1	Air Regulator Body ¹	1	70-8500-20	70-8500-20	70-8500-20	70-8500-20
2	Glyd™ Ring	3	08-3210-55-225	08-3210-55-225	08-3210-55-225	08-3210-55-225
3	Reducer Bushing 1 1/4 x 1/2 NPT	1	70-6950-08	70-6950-08	70-6950-05	70-6950-05
4	Shaft Bolt 1/2-20 x 1	1	04-6090-08	04-6090-08	04-6090-08	04-6090-08
5	Flat Washer	1	70-6790-08	70-6790-08	70-6790-08	70-6790-08
6	Center Block Gasket	1	04-3520-52	04-3520-52	04-3520-52	04-3520-52
7	Air Chamber	1	04-3650-08	04-3650-08	04-3650-05	04-3650-05
8	Socket Head Cap Screw 1/4-20 x 7/8	3	70-6250-03	70-6250-03	70-6250-03	70-6250-03
9	Shaft	1	04-3820-03-07	04-3820-03-07	04-3820-03-07	04-3820-03-07
10	Stop	1	70-8800-17	70-8800-17	70-8800-17	70-8800-17
11	Inner Piston	1	04-3700-08	04-3750-01	04-3700-08	04-3750-01
12	Back Up Diaphragm	1	N/R	04-1060-51	N/R	04-1060-51
13	Diaphragm	1	2*	04-1010-552	2*	04-1010-55²
14	Shaft Stud 1/2-20 x 1 1/2 All Thd	1	N/R	N/R	N/R	N/R
15	Outer Piston	1	04-4550-21-500	04-4600-21-500	04-4550-21-500	04-4600-21-500
16	Large Clamp Band Assembly	1	04-7330-03	04-7330-03	04-7330-05	04-7330-05
17	Hex Nut 5/16-18	2	08-6400-03	08-6400-03	08-6400-05	08-6400-05
18	Carriage Bolt 5/16-18 x 2 1/2	2	04-6070-03	04-6070-03	04-6070-05	04-6070-05
19	Small Clamp Band Assembly	2	04-7100-03-500	04-7100-03-500	04-7100-05-500	04-7100-05-500
20	Hex Nut 5/16-18	4	08-6400-03	08-6400-03	08-6400-05	08-6400-05
21	Carriage Bolt 5/16-18 x 2	4	08-6050-03-500	08-6050-03-500	08-6050-05-500	08-6050-05-500
22	Liquid Chamber	1	04-5000-21	04-5000-21	04-5000-21	04-5000-21
23	Surge End	1	70-8600-21	70-8600-21	70-8600-21	70-8600-21
24	Surge End	1	70-8600-21	70-8600-21	70-8600-21	70-8600-21
25	Surge End O-Ring	2	*	70-1270-60	*	70-1270-60

¹Air Regulator Body includes qty. 3 shaft Glyd™-rings. **All bold face items are primary wear parts.**

²Teflon® Gasket Kit, P/N 04-9500-99, required.

*Elastomer options listed on page 30.

SD1 EQUALIZER®
Teflon® PFA Construction

ITEM	PART DESCRIPTION	QTY.	TMP-VT	TMP-TF	TMP-VT-502	TMP-TF-502
1	Air Regulator Body ¹	1	70-8500-20	70-8500-20	70-8500-20	70-8500-20
2	Glyd™ Ring	3	08-3210-55-225	08-3210-55-225	08-3210-55-225	08-3210-55-225
3	Reducer Bushing 1 1/4 x 1/2 NPT	1	70-6950-08	70-6950-08	70-6950-05	70-6950-05
4	Shaft Bolt 1/2-20 x 1	1	04-6090-08	04-6090-08	04-6090-08	04-6090-08
5	Flat Washer	1	70-6790-08	70-6790-08	70-6790-08	70-6790-08
6	Center Block Gasket	1	04-3520-52	04-3520-52	04-3520-52	04-3520-52
7	Air Chamber	1	04-3650-08	04-3650-08	04-3650-05	04-3650-05
8	Socket Head Cap Screw 1/4-20 x 7/8	3	70-6250-03	70-6250-03	70-6250-03	70-6250-03
9	Shaft	1	04-3820-03-07	04-3820-03-07	04-3820-03-07	04-3820-03-07
10	Stop	1	70-8800-17	70-8800-17	70-8800-17	70-8800-17
11	Inner Piston	1	04-3700-08	04-3750-01	04-3700-08	04-3750-01
12	Back Up Diaphragm	1	N/R	04-1060-51	N/R	04-1060-51
13	Diaphragm²	1	04-1010-53	04-1010-55	04-1010-53	04-1010-55
14	Shaft Stud 1/2-20 x 1 1/2 All Thd	1	N/R	N/R	N/R	N/R
15	Outer Piston	1	04-4550-22-500	04-4600-22-500	04-4550-22-500	04-4600-22-500
16	Large Clamp Band Assembly	1	04-7330-03	04-7330-03	04-7330-05	04-7330-05
17	Hex Nut 5/16-18	2	08-6400-03	08-6400-03	08-6400-05	08-6400-05
18	Carriage Bolt 5/16-18 x 2 1/2	2	04-6070-03	04-6070-03	04-6070-05	04-6070-05
19	Small Clamp Band Assembly	2	04-7100-03-500	04-7100-03-500	04-7100-05-500	04-7100-05-500
20	Hex Nut 5/16-18	4	08-6400-03	08-6400-03	08-6400-05	08-6400-05
21	Carriage Bolt 5/16-18 x 2	4	08-6050-03-500	08-6050-03-500	08-6050-05-500	08-6050-05-500
22	Liquid Chamber	1	04-5000-22	04-5000-22	04-5000-22	04-5000-22
23	Surge End	1	70-8600-55	70-8600-55	70-8600-55	70-8600-55
24	Surge End	1	70-8600-55	70-8600-55	70-8600-55	70-8600-55
25	Surge End O-Ring	2	70-1270-60	70-1270-60	70-1270-60	70-1270-60

¹Air Regulator Body includes qty. 3 shaft Glyd™-rings.

²Teflon® Gasket Kit, P/N 04-9500-99, required.

All bold face items are primary wear parts.

SD2 EQUALIZER® Aluminum Construction

ITEM	PART DESCRIPTION	QTY.	ALUMINUM AAP	ALUMINUM AAP-TF
1	Air Regulator Body ¹	1	70-8500-20	70-8500-20
2	Glyd™ Ring	3	08-3210-55-225	08-3210-55-225
3	Reducer Bushing 1 1/4 x 1/2 NPT	1	70-6950-08	70-6950-08
4	Shaft Bolt 1/2-20 x 1	1	04-6090-08	04-6090-08
5	Flat Washer	1	70-6790-08	70-6790-08
6	Center Block Gasket	1	71-3520-30	71-3520-30
7	Air Chamber for SD2	1	71-3650-01	71-3650-01
8	Flat Head Cap Screw 3/8-16 x 1	4	71-6250-08	71-6250-08
9	Shaft	1	04-3820-03-07	04-3820-03-07
10	Stop	1	71-8800-17	71-8800-17
11	Inner Piston	1	04-3700-08	08-3750-01
12	Back Up Diaphragm	1	N/R	08-1060-51
13	Diaphragm	1	*	08-1010-55
14	Shaft Bolt	1	N/R	08-6150-08
15	Outer Piston	1	04-4552-01	08-4600-01
16	Large Clamp Band Assembly	1	08-7300-08	08-7300-03
17	Hex Nut Heavy 3/8-16	2	08-6450-08	08-6450-03
18	Hex Head Cap Screw 3/8-16 x 3	2	08-6120-08	08-6120-03
19	Small Clamp Assembly	2	08-7100-08	08-7100-03
20	Hex Nut 5/16-18	4	04-6420-08	08-6400-03
21	Hex Head Cap Screw 5/16-18 x 1 3/8	4	08-6050-08	08-6030-03
22	Liquid Chamber	1	08-5000-01	08-5000-01
23	Surge End	1	71-8600-01	71-8600-01
24	Surge End	1	71-8600-01	71-8600-01
25	Surge End O-Ring	2	*	71-1280-55

¹Air Regulator Body includes qty. 3 shaft Glyd™-rings. **All bold face items are primary wear parts.**

²Teflon® Gasket Kit, P/N 08-9500-99, required.

SD2 EQUALIZER® Cast Iron Construction

ITEM	PART DESCRIPTION	QTY.	CAST IRON WAP	CAST IRON WWP	CAST IRON WAP-TF	CAST IRON WWP-TF
1	Air Regulator Body ¹	1	70-8500-20	70-8500-20	70-8500-20	70-8500-20
2	Glyd™ Ring	3	08-3210-55-225	08-3210-55-225	08-3210-55-225	08-3210-55-225
3	Reducer Bushing 1 1/4 x 1/2 NPT	1	70-6950-08	70-6950-08	70-6950-08	70-6950-08
4	Shaft Bolt 1/2-20 x 1	1	04-6090-08	04-6090-08	04-6090-08	04-6090-08
5	Flat Washer	1	70-6790-08	70-6790-08	70-6790-08	70-6790-08
6	Center Block Gasket	1	71-3520-30	71-3520-30	71-3520-30	71-3520-30
7	Air Chamber for SD2	1	71-3650-01	71-3650-02	71-3650-01	71-3650-02
8	Flat Head Cap Screw 3/8-16 x 1	4	71-6250-08	71-6250-08	71-6250-08	71-6250-08
9	Shaft	1	04-3820-03-07	04-3820-03-07	04-3820-03-07	04-3820-03-07
10	Stop	1	71-8800-17	71-8800-17	71-8800-17	71-8800-17
11	Inner Piston	1	04-3700-08	04-3700-08	08-3750-01	08-3750-01
12	Back Up Diaphragm	1	N/R	N/R	08-1060-51	08-1060-51
13	Diaphragm	1	2*	2*	08-1010-55	08-1010-55
14	Shaft Bolt 1/2-20 x 1	1	04-6090-08	04-6090-08	08-6150-08	08-6150-08
	Shaft Bolt Washer	1	04-6800-08	04-6800-08	N/R	N/R
15	Outer Piston	1	04-4550-08	04-4550-08	08-4600-03	08-4600-03
16	Large Clamp Band Assembly	1	08-7300-08	08-7300-03	08-7300-03	08-7300-03
17	Hex Nut Heavy 3/8-16	2	08-6450-08	08-6450-03	08-6450-03	08-6450-03
18	Hex Head Cap Screw 3/8-16 x 3	2	08-6120-08	08-6120-03	08-6120-03	08-6120-03
19	Small Clamp Band Assembly	2	08-7100-08	08-7100-03	08-7100-03	08-7100-03
20	Hex Nut 5/16-18	4	04-6420-08	08-6400-03	08-6400-03	08-6400-03
21	Hex Head Cap Screw 5/16-18 x 1 3/8	4	08-6050-08	08-6050-03	08-6050-03	08-6050-03
22	Liquid Chamber	1	08-5000-02	08-5000-02	08-5000-02	08-5000-02
23	Surge End	1	71-8600-03	71-8600-03	71-8600-03	71-8600-03
24	Surge End	1	71-8600-03	71-8600-03	71-8600-03	71-8600-03
25	Surge End O-Ring	2	*	*	71-1280-55	71-1280-55

¹Air Regulator Body includes qty. 3 shaft Glyd™-rings.

²Teflon® Gasket Kit, P/N 08-9500-99, required.

*Elastomer options listed on page 30.

All bold face items are primary wear parts.

SD2 EQUALIZER® Stainless Steel Construction

ITEM	PART DESCRIPTION	QTY.	316 S.S. SAP	316 S.S. SSP	316 S.S. SAP-TF	316 S.S. SSP-TF
1	Air Regulator Body ¹	1	70-8500-20	70-8500-20	70-8500-20	70-8500-20
2	Glyd™ Ring	3	08-3210-55-225	08-3210-55-225	08-3210-55-225	08-3210-55-225
3	Reducer Bushing 1 1/4 x 1/2 NPT	1	70-6950-08	70-6950-08	70-6950-08	70-6950-08
4	Shaft Bolt 1/2-20 x 1	1	04-6090-08	04-6090-08	04-6090-08	04-6090-08
5	Flat Washer	1	70-6790-08	70-6790-08	70-6790-08	70-6790-08
6	Center Block Gasket	1	71-3520-30	71-3520-30	71-3520-30	71-3520-30
7	Air Chamber for SD2	1	71-3650-01	71-3650-03	71-3650-01	71-3650-03
8	Flat Head Cap Screw 3/8-16 x 1	4	71-6250-08	71-6250-08	71-6250-08	71-6250-08
9	Shaft	1	04-3820-03-07	04-3820-03-07	04-3820-03-07	04-3820-03-07
10	Stop	1	71-8800-17	71-8800-17	71-8800-17	71-8800-17
11	Inner Piston	1	04-3700-08	04-3700-08	08-3750-01	08-3750-01
12	Back Up Diaphragm	1	N/R	N/R	08-1060-51	08-1060-51
13	Diaphragm	1	2*	2*	08-1010-55	08-1010-55
14	Shaft Stud 1/2-20 x 1 1/2 All Thd	1	04-6150-08	04-6150-08	08-6150-08	08-6150-08
15	Outer Piston	1	04-4550-03	04-4550-03	08-4600-03	08-4600-03
16	Large Clamp Band Assembly	1	08-7300-03	08-7300-03	08-7300-03	08-7300-03
17	Hex Nut Heavy 3/8-16	2	08-6450-03	08-6450-03	08-6450-03	08-6450-03
18	Hex Head Cap Screw 3/8-16 x 2 3/4	2	08-6120-03	08-6120-03	08-6120-03	08-6120-03
19	Small Clamp Band Assembly	2	08-7100-03	08-7100-03	08-7100-03	08-7100-03
20	Hex Nut 5/16-18	4	08-6400-03	08-6400-03	08-6400-03	08-6400-03
21	Hex Head Cap Screw 5/16-18 x 1 3/8	4	08-6050-03	08-6050-03	08-6050-03	08-6050-03
22	Liquid Chamber	1	08-5000-03	08-5000-03	08-5000-03	08-5000-03
23	Surge End	1	71-8600-03	71-8600-03	71-8600-03	71-8600-03
24	Surge End	1	71-8600-03	70-8600-03	71-8600-03	71-8600-03
25	Surge End O-Ring	2	*	*	71-1280-55	71-1280-55

¹Air Regulator Body includes qty. 3 shaft Glyd™-rings. **All bold face items are primary wear parts.**

²Teflon® Gasket Kit, P/N 08-9500-99, required.

SD2 BOLTED EQUALIZER® Stainless Steel Bolted Construction with PTFE Diaphragms

ITEM	PART DESCRIPTION	QTY.	SSP-TF-040	HSP-TF-040
1	Air Regulator Body	1	70-8500-20	70-8500-20
2	Glyd™ Ring	3	08-3210-55-225	08-3210-55-225
3	Reducer Bushing	1	70-6950-08	70-6950-08
4	Screw, HHC, 1/2-20 x 1	1	04-6090-08	04-6090-08
5	Washer (.53 X 1.38 x.17)	1	70-6790-08	70-6790-08
6	Center Block Gasket	1	71-3520-30	71-3520-30
7	Air Chamber	1	71-3650-03-42	71-3650-03-42
8	Screw, HSFHS, 3/8-16 x 1	4	71-6250-08	71-6250-08
9	Shaft	1	04-3820-03-07	04-3820-03-07
10	Stop	1	71-8800-17	71-8800-17
11	Inner Piston	1	08-3750-01	08-3750-01
12	Back Up Diaphragm	1	08-1060-51	08-1060-51
13	Primary Diaphragm	1	08-1010-55-42	08-1010-55-42
14	Stud, 1/2-20 x 1 7/8	1	08-6150-08	08-6150-08
15	Outer Piston	1	08-4600-03	08-4600-04
16	Liquid Chamber	1	71-5000-03-42	71-5000-04-42
17	Washer, Flat(.390 X .625 x .063)	14	02-6730-03	02-6730-03
18	Screw, HHC, 3/8-16 x 1 1/2	14	08-6190-03-42	08-6190-03-42
19	Nut, Hex, 3/8-16	14	02-6430-03	02-6430-03
20	Washer, Disc Spring(.380 x .750)	14	08-6820-03-42	08-6820-03-42

NOTE: Teflon Gasket Kit not required on Bolted Dampeners

All bold face items are primary wear parts.

SD2 EQUALIZER® Polypropylene Construction

ITEM	PART DESCRIPTION	QTY.	POLY P PAP	POLY P PAP-TF	POLY P PCP-502	POLY P PCP-TF-502
1	Air Regulator Body ¹	1	70-8500-20	70-8500-20	70-8500-20	70-8500-20
2	Glyd™ Ring	3	08-3210-55-225	08-3210-55-225	08-3210-55-225	08-3210-55-225
3	Reducer Bushing 1 1/4 x 1/2 NPT	1	70-6950-08	70-6950-08	70-6950-05	70-6950-05
4	Shaft Bolt 1/2-20 x 1	1	04-6090-08	04-6090-08	04-6090-08	04-6090-08
5	Flat Washer	1	70-6790-08	70-6790-08	70-6790-08	70-6790-08
6	Center Block Gasket	1	71-3520-30	71-3520-30	71-3520-30	71-3520-30
7	Air Chamber for SD2	1	71-3650-01	71-3650-01	71-3650-05	71-3650-05
8	Flat Head Cap Screw 3/8-16 x 1	4	71-6250-08	71-6250-08	71-6250-08	71-6250-08
9	Shaft	1	04-3820-03-07	04-3820-03-07	04-3820-03-07	04-3820-03-07
10	Stop	1	71-8800-17	71-8800-17	71-8800-17	71-8800-17
11	Inner Piston	1	04-3700-08	08-3750-01	04-3700-08	08-3750-01
12	Back Up Diaphragm	1	N/R	08-1060-51	N/R	08-1060-51
13	Diaphragm²	1	*	08-1010-55	*	08-1010-55
14	Shaft Stud 1/2-20 x 1 1/2 All Thd	1	N/R	N/R	N/R	N/R
15	Outer Piston	1	04-4550-20-500	08-4600-21-500	04-4550-20-500	08-4600-21-500
16	Large Clamp Band Assembly	1	08-7300-03-500	08-7300-03-500	08-7300-05-500	08-7300-05-500
17	Hex Nut Heavy 3/8-16	2	08-6450-03	08-6450-03	08-6420-05	08-6420-05
18	Carriage Bolt 3/8-16 x 2 1/2	2	08-6070-03-500	08-6070-03-500	08-6070-05-500	08-6070-05-500
19	Small Clamp Band Assembly	2	08-7200-03-500	08-7200-03-500	08-7200-05-500	08-7200-05-500
20	Hex Nut 5/16-18	4	08-6400-03	08-6400-03	08-6400-05	08-6400-05
21	Hex Head Cap Screw 5/16-18 x 2 1/2	4	04-6070-03	04-6070-03	04-6070-05	04-6070-05
22	Liquid Chamber	1	08-5000-20	08-5000-20	08-5000-20	08-5000-20
23	Surge End, Inlet	1	71-8700-20	71-8700-20	71-8700-20	71-8700-20
24	Surge End, Discharge	1	71-8710-20	71-8710-20	71-8710-20	71-8710-20
25	Surge End O-Ring	2	*	71-1270-60	*	71-1270-60

¹Air Regulator Body includes qty. 3 shaft Glyd™-rings. **All bold face items are primary wear parts.**

²Teflon® Gasket Kit, P/N 08-9500-99, required.

SD2 EQUALIZER® PVDF Construction

ITEM	PART DESCRIPTION	QTY.	PVDF K KAP	PVDF K KAP-TF	PVDF K KCP-502	PVDF K KCP-TF-502
1	Air Regulator Body ¹	1	70-8500-20	70-8500-20	70-8500-20	70-8500-20
2	Glyd™ Ring	3	08-3210-55-225	08-3210-55-225	08-3210-55-225	08-3210-55-225
3	Reducer Bushing 1 1/4 x 1/2 NPT	1	70-6950-08	70-6950-08	70-6950-05	70-6950-05
4	Shaft Bolt 1/2-20 x 1	1	04-6090-08	04-6090-08	04-6090-08	04-6090-08
5	Flat Washer	1	70-6790-08	70-6790-08	70-6790-08	70-6790-08
6	Center Block Gasket	1	71-3520-30	71-3520-30	71-3520-30	71-3520-30
7	Air Chamber for SD2	1	71-3650-01	71-3650-01	71-3650-05	71-3650-05
8	Flat Head Cap Screw 3/8-16 x 1	4	71-6250-08	71-6250-08	71-6250-08	71-6250-08
9	Shaft	1	04-3820-03-07	04-3820-03-07	04-3820-03-07	04-3820-03-07
10	Stop	1	71-8800-17	71-8800-17	71-8800-17	71-8800-17
11	Inner Piston	1	04-3700-08	08-3750-01	04-3700-08	08-3750-01
12	Back Up Diaphragm	1	N/R	08-1060-51	N/R	08-1060-51
13	Diaphragm²	1	*	08-1010-55	*	08-1010-55
14	Shaft Stud 1/2-20 x 1 1/2 All Thd	1	N/R	N/R	N/R	N/R
15	Outer Piston	1	04-4550-21-500	08-4600-21-500	04-4550-21-500	08-4600-21-500
16	Large Clamp Band Assembly	1	08-7300-03-500	08-7300-03-500	08-7300-05-500	08-7300-05-500
17	Hex Nut Heavy 3/8-16	2	08-6450-03	08-6450-03	08-6420-05	08-6420-05
18	Carriage Bolt 3/8-16 x 2 1/2	2	08-6070-03-500	08-6070-03-500	08-6070-05-500	08-6070-05-500
19	Small Clamp Band Assembly	2	08-7200-03-500	08-7200-03-500	08-7200-05-500	08-7200-05-500
20	Hex Nut 5/16-18	4	08-6400-03	08-6400-03	08-6400-05	08-6400-05
21	Hex Head Cap Screw 5/16-18 x 2 1/2	4	04-6070-03	04-6070-03	04-6070-05	04-6070-05
22	Liquid Chamber	1	08-5000-21	08-5000-21	08-5000-21	08-5000-21
23	Surge End, Inlet	1	71-8700-21	71-8700-21	71-8700-21	71-8700-21
24	Surge End, Discharge	1	71-8710-21	71-8710-21	71-8710-21	71-8710-21
25	Surge End O-Ring	2	*	71-1270-60	*	71-1270-60

¹Air Regulator Body includes qty. 3 shaft Glyd™-rings.

²Teflon® Gasket Kit, P/N 08-9500-99, required.

*Elastomer options listed on page 30.

All bold face items are primary wear parts.

NOTES:

THE EQUALIZER®

SD3

Exploded View

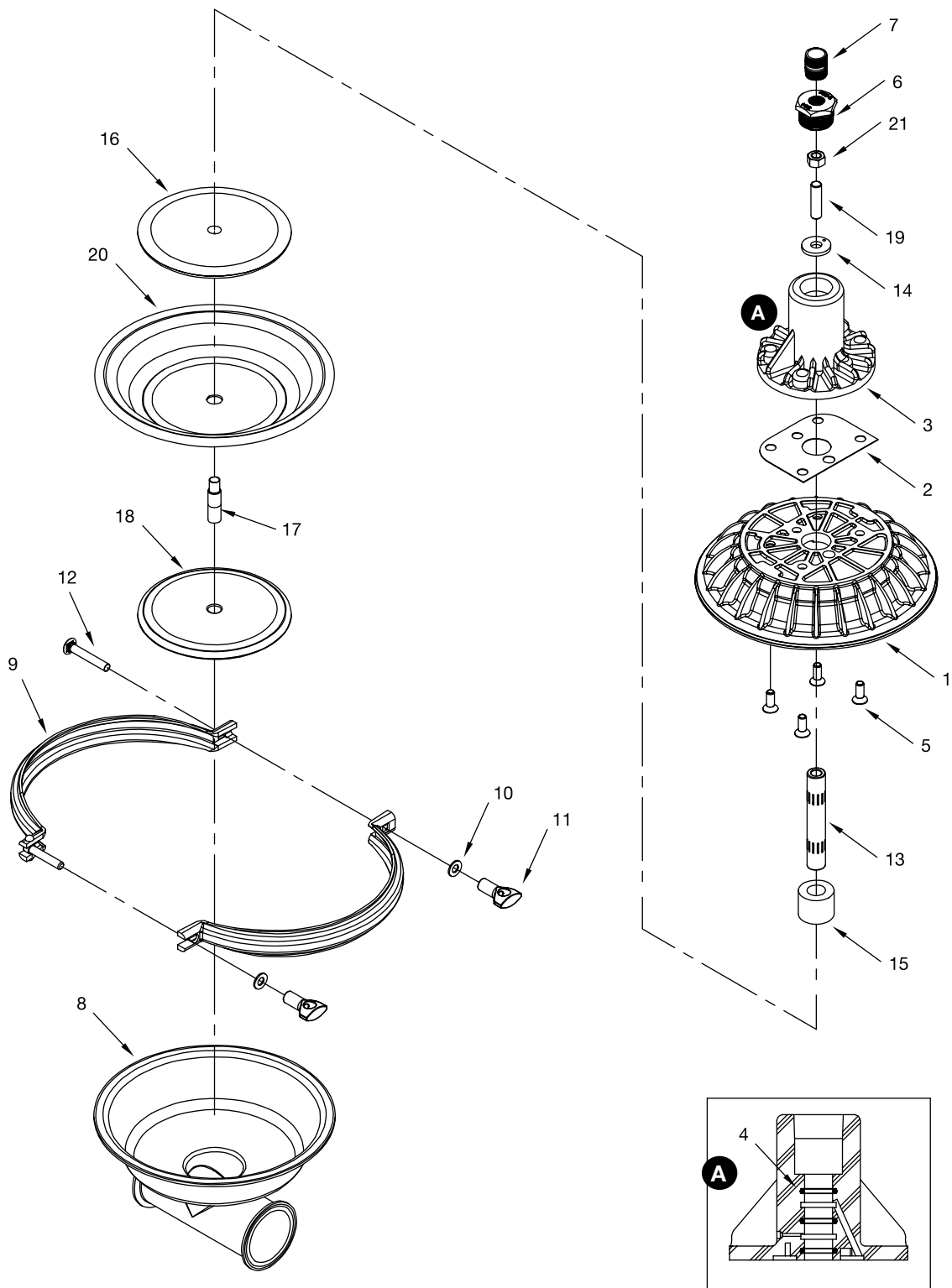

SD3 SANIFLO™ EQUALIZER®
Stainless Steel Construction

ITEM	PART DESCRIPTION	QTY.	SD3-SNP	SD3-SSP
1	AIR CHAMBER, SD2	1	71-3650-06	71-3650-03
2	CENTER BLOCK GASKET	1	71-3520-30	71-3520-30
3	AIR REGULATOR BODY1	1	70-8500-20	70-8500-20
4	GLYD™ RING II	3	08-3210-55-225	08-3210-55-225
5	FLAT HEAD CAP SCREW, 3/8-16 X 1	4	71-6250-03	71-6250-03
6	REDUCER BUSHING	1	71-6950-03	71-6950-03
7	THREADED NIPPLE, 1/2"	1	71-7421-03	71-7421-03
8	LIQUID CHAMBER, LSH	1	15-5000-10-83	15-5000-10-83
9	LARGE CLAMP BAND ASSY	1	08-7300-03-83	08-7300-03-83
10	FLAT WASHER (.406 x .875 x .125)	2	04-6741-03	04-6741-03
11	WING NUT, LARGE	2	08-6671-10	08-6671-10
12	CARRIAGE BOLT, 3/8-16 X 2 1/2"	1	08-6070-03-500	08-6070-03-500
13	SHAFT	1	04-3820-03-07	04-3820-03-07
14	WASHER, STOP (.53 x 1.38 x .17)	1	70-6790-08	70-6790-08
15	STOP	1	71-8800-17	71-8800-17
16	INNER PISTON	1	08-3700-01	08-3700-01
17	ADAPTER, SHAFT STUD	1	71-6153-08	71-6153-08
18	OUTER PISTON	1	08-4550-10-72	08-4550-10-72
19	SHAFT STUD, 1/2-20 x 1 7/8"	1	08-6150-08	08-6150-08
20	DIAPHRAGM	1	*	*
21	HEX NUT, 1/2-20	1	71-6460-08	71-6460-08

¹Air Regulator Body includes qty. 3 shaft Glyd™-rings (Item 4). **All bold face items are primary wear parts.**

*See Elastomer chart for material options.

ELASTOMER OPTIONS

	ELASTOMER	DIAPHRAGM	BACK-UP DIAPHRAGM	O-RINGS
METAL AND PLASTIC SD½ EQUALIZER®	Teflon® PTFE	01-1010-55	NA	NA
	Buna-N	01-1010-52	NA	NA
	Viton®	01-1010-53	NA	NA
	Saniflex™	01-1010-56	NA	NA
	Wil-Flex™	01-1010-58	NA	NA
	Neoprene	—	01-1060-51	NA
METAL SD1 EQUALIZER®	Teflon® PTFE	04-1010-55	NA	70-1280-55
	Buna-N	04-1010-52	NA	70-1280-52
	Neoprene	04-1010-51	04-1060-51	NA
	Nordel®	04-1010-54	NA	NA
	Viton®	04-1010-53	NA	NA
	Wil-Flex™	04-1010-58	NA	NA
	Saniflex™	04-1010-56	04-1060-56	NA
PLASTIC SD1 EQUALIZER®	Teflon® PTFE	04-1010-55	NA	NA
	Teflon® Encapsulated Viton®	NA	NA	70-1270-60
	Buna-N	04-1010-52	NA	70-1270-52
	Neoprene	04-1010-51	04-1060-51	NA
	Nordel®	04-1010-54	NA	NA
	Viton®	04-1010-53	NA	NA
	Wil-Flex™	04-1010-58	NA	NA
	Saniflex™	04-1010-56	04-1060-56	NA
METAL SD2 EQUALIZER®	Teflon® PTFE	08-1010-55	NA	71-1281-55
	Buna-N	08-1010-52-06	NA	71-1281-52
	Neoprene	08-1010-51-06	08-1060-51	NA
	Nordel®	08-1010-54-06	NA	NA
	Viton®	08-1010-53-06	NA	NA
	Saniflex™	N/A	08-1060-56	NA
PLASTIC SD2 EQUALIZER®	Teflon® PTFE	08-1010-55	NA	NA
	Teflon® Encapsulated Viton®	NA	NA	71-1270-60
	Buna-N	08-1010-52-06	NA	71-1270-52
	Neoprene	08-1010-51-06	08-1060-51	NA
	Nordel®	08-1010-54-06	NA	NA
	Viton®	08-1010-53-06	NA	NA
	Saniflex™	N/A	08-1060-56	NA
METAL SD3 SANIFLO™ EQUALIZER®	Saniflex™	08-1010-56	NA	NA
	30FDA Wil-Flex™	08-1010-57	NA	NA
	FDA Buna-N	08-1010-69	NA	NA
	FDA Nordel®	08-1010-74	NA	NA

Buna-N, Nordel and Viton are registered trademarks of DuPont Dow Elastomers.
Teflon is a registered trademark of DuPont.

TORQUE SPECIFICATIONS

METAL AND PLASTIC SD½ EQUALIZER®	DESCRIPTION OF PART	MAXIMUM TORQUE
	Air Regulator Body	75 in.-lbs. [8 m-N]
	Outer Piston	75 in.-lbs. [8 m-N]
	Clamp Band Assembly — Rubber-Fitted	65 in.-lbs. [7.4 m-N]
	Clamp Band Assembly — Teflon®-Fitted	85 in.-lbs. [9.6 m-N]
METAL SD1 EQUALIZER®	Air Regulator Body	11 ft.-lbs. [14.9 m-N]
	Shaft Assembly	33 ft.-lbs. [44.7 m-N]
	Small Clamp Band	30 in.-lbs. [3.4 m-N]
	Large Clamp Band — Rubber	100 in.-lbs. [11.3 m-N]
	Large Clamp Band — Teflon®	120 in.-lbs. [13.6 m-N]
PLASTIC SD1 EQUALIZER®	Air Regulator Body	11 ft.-lbs. [14.9 m-N]
	Shaft Assembly	33 ft.-lbs. [44.7 m-N]
	Small Clamp Bands	85 in.-lbs. [9.6 m-N]
	Large Clamp Bands	165 in.-lbs. [18.6 m-N]
METAL SD2 EQUALIZER®	Air Regulator Body	28 ft.-lbs. [38.0 m-N]
	Shaft Assembly — Rubber	33 ft.-lbs. [44.7 m-N]
	Shaft Assembly — Teflon®	58 ft.-lbs. [78.6 m-N]
	Small Clamp Band — Rubber	27 in.-lbs. [3.0 m-N]
	Small Clamp Band — Teflon®	58 in.-lbs. [6.6 m-N]
	Large Clamp Band	28 ft.-lbs. [38.0 m-N]
PLASTIC SD2 EQUALIZER®	Air Regulator Body	28 ft.-lbs. [38.0 m-N]
	Shaft Assembly — Rubber	33 ft.-lbs. [44.7 m-N]
	Shaft Assembly — Teflon®	58 ft.-lbs. [78.6 m-N]
	Small Clamp Band	90 in.-lbs. [10.2 m-N]
	Large Clamp Band	28 ft.-lbs. [38.0 m-N]
METAL SD2 BOLTED EQUALIZER®	Air Regulator Body	28 ft.-lbs. [38.0 m-N]
	Shaft Assembly - Rubber	33 ft.-lbs.[44.7 m-N]
	Shaft Assembly - Teflon®	58 ft.-lbs. [78.6 m-N]
	Liquid to Air Chamber	20 ft.-lbs. [27.1 m-N]
METAL SD3 SANIFLO™ EQUALIZER®	Air Regulator Body	28 ft.-lbs. [38.0 m-N]
	Shaft Assembly - Rubber	33 ft.-lbs.[44.7 m-N]
	Shaft Assembly - Teflon®	58 ft.-lbs. [78.6 m-N]
	Liquid to Air Chamber	N/A

PRESSURE VARIATION BAND

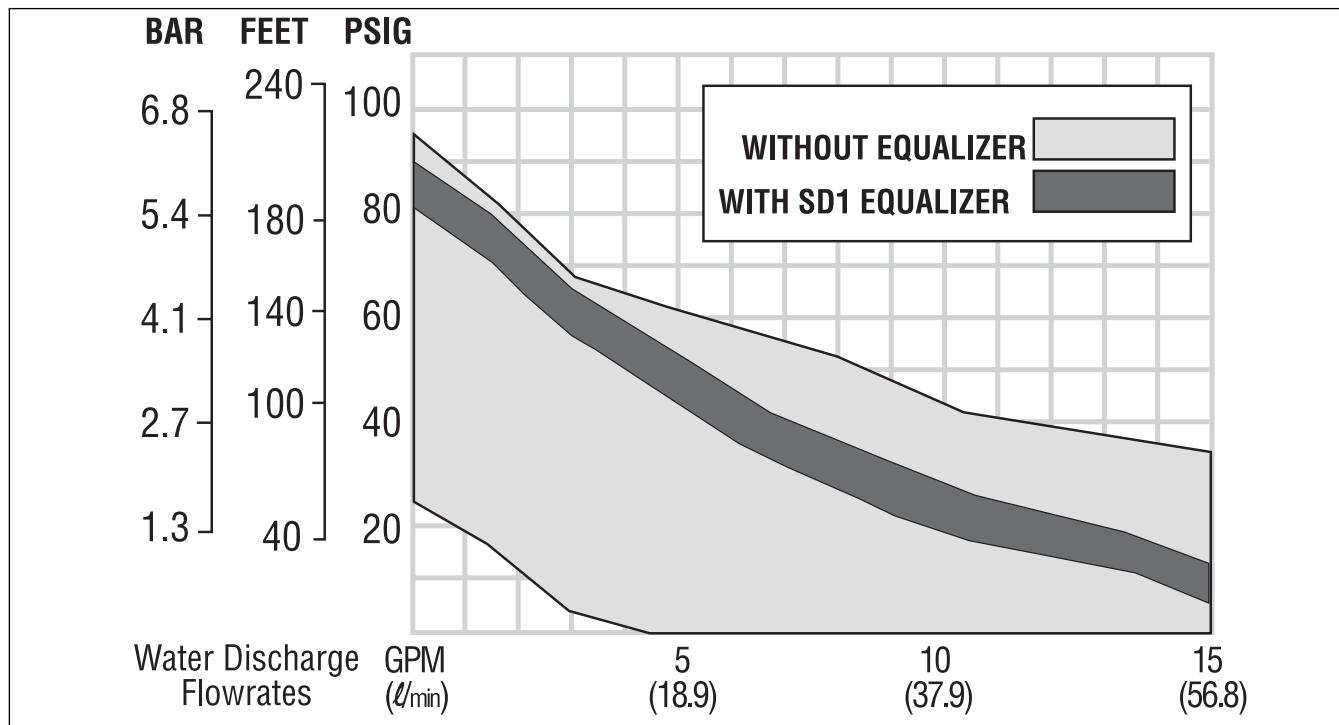

The above curve reflects the discharge pressure variation of a Wilden model T1 compared to an T1 with the Equalizer® (model SD1) installed. Plotted data points were obtained from an Oscilloscope.

WARRANTY

Each and every product manufactured by Wilden Pump and Engineering, LLC is built to meet the highest standards of quality. Every pump is functionally tested to insure integrity of operation.

Wilden Pump and Engineering, LLC warrants that pumps, accessories and parts manufactured or supplied by it to be free from defects in material and workmanship for a period of five (5) years from date of installation or six (6) years from date of manufacture, whichever comes first. Failure due to normal wear, misapplication, or abuse is, of course, excluded from this warranty.

Since the use of Wilden pumps and parts is beyond our control, we cannot guarantee the suitability of any pump or part for a particular application and Wilden Pump and Engineering, LLC shall not be liable for any consequential damage or expense arising from the use or misuse of its products on any application. Responsibility is limited solely to replacement or repair of defective Wilden pumps and parts.

All decisions as to the cause of failure are the sole determination of Wilden Pump and Engineering, LLC.

Prior approval must be obtained from Wilden for return of any items for warranty consideration and must be accompanied by the appropriate MSDS for the product(s) involved. A Return Goods Tag, obtained from an authorized Wilden distributor, must be included with the items which must be shipped freight prepaid.

The foregoing warranty is exclusive and in lieu of all other warranties expressed or implied (whether written or oral) including all implied warranties of merchantability and fitness for any particular purpose. No distributor or other person is authorized to assume any liability or obligation for Wilden Pump and Engineering, LLC other than expressly provided herein.

PLEASE PRINT OR TYPE AND FAX TO WILDEN

PUMP INFORMATION			
Item # _____	Serial # _____		
Company Where Purchased _____			
YOUR INFORMATION			
Company Name _____			
Industry _____			
Name _____	Title _____		
Street Address _____			
City _____	State _____	Postal Code _____	Country _____
Telephone _____	Fax _____	E-mail _____	Web Address _____
Number of pumps in facility? _____		Number of Wilden pumps? _____	
Types of pumps in facility (check all that apply): <input type="checkbox"/> Diaphragm <input type="checkbox"/> Centrifugal <input type="checkbox"/> Gear <input type="checkbox"/> Submersible <input type="checkbox"/> Lobe			
<input type="checkbox"/> Other _____			
Media being pumped? _____			
How did you hear of Wilden Pump? <input type="checkbox"/> Trade Journal <input type="checkbox"/> Trade Show <input type="checkbox"/> Internet/E-mail <input type="checkbox"/> Distributor			
<input type="checkbox"/> Other _____			

ONCE COMPLETE, FAX TO (909) 783-3440

NOTE: WARRANTY VOID IF PAGE IS NOT FAXED TO WILDEN

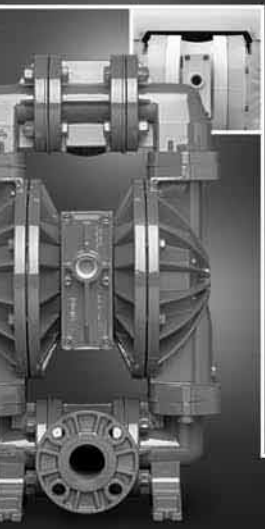

ADVANCED S E R I E S

Advance Your Process

- Advanced wetted path designs
- Lower the cost of operation
- Maximize product containment
- Longer MTBF (Mean Time Between Failures)
- Enhanced internal clearance
- The result of advanced thought

UNITEC™ B E R I E S

Enrich Your Process

- Simplicity of design
- Unique Technology
- Reliable, leak-free & quiet
- Validated & certified
- Intrinsically safe
- The result of unique thought

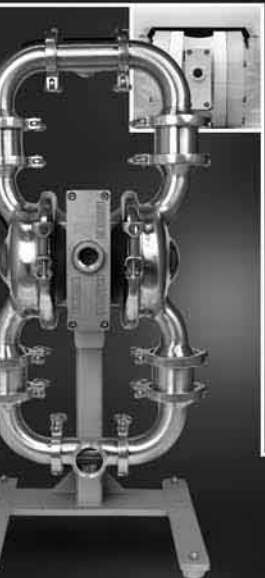
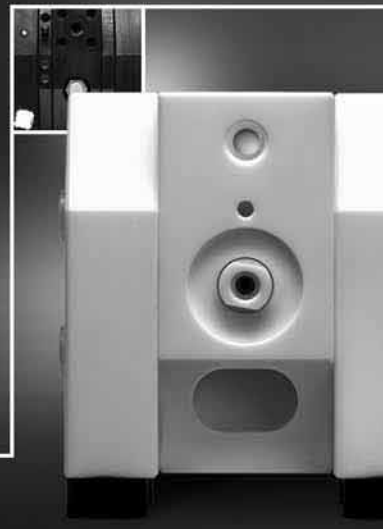

SANIFLO™ S A N I T A R Y P U M P T E C H N O L O G Y

Refine Your Process

- Designed for sanitary applications
- Minimize product degradation
- Improved production yields
- Easy to inspect, clean & assemble
- Minimized water requirements
- The result of progressive thought

ACCESSORIES

Maximize Your Process

- Electronic control & monitoring
- Level control & containment
- Pulsation dampening
- Drum unloading systems
- Complete system solutions
- The result of innovative thought

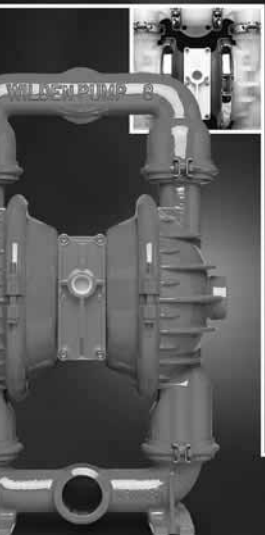

ORIGINAL S E R I E S

Simplify Your Process

- Long standing design simplicity
- Portable & submersible
- Variable connection options
- Fewest parts in industry
- Solutions since 1955
- The result of original thought



WILDEN®

A DOVER COMPANY

22069 VAN BUREN STREET • GRAND TERRACE, CA 92313-5607
(909) 422-1730 • FAX (909) 783-3440
www.wildenpump.com

Your Local Authorized Distributor: