

P1

EOM

Engineering
Operation &
Maintenance

Original™ Series **PLASTIC** Pumps



Simplify your process

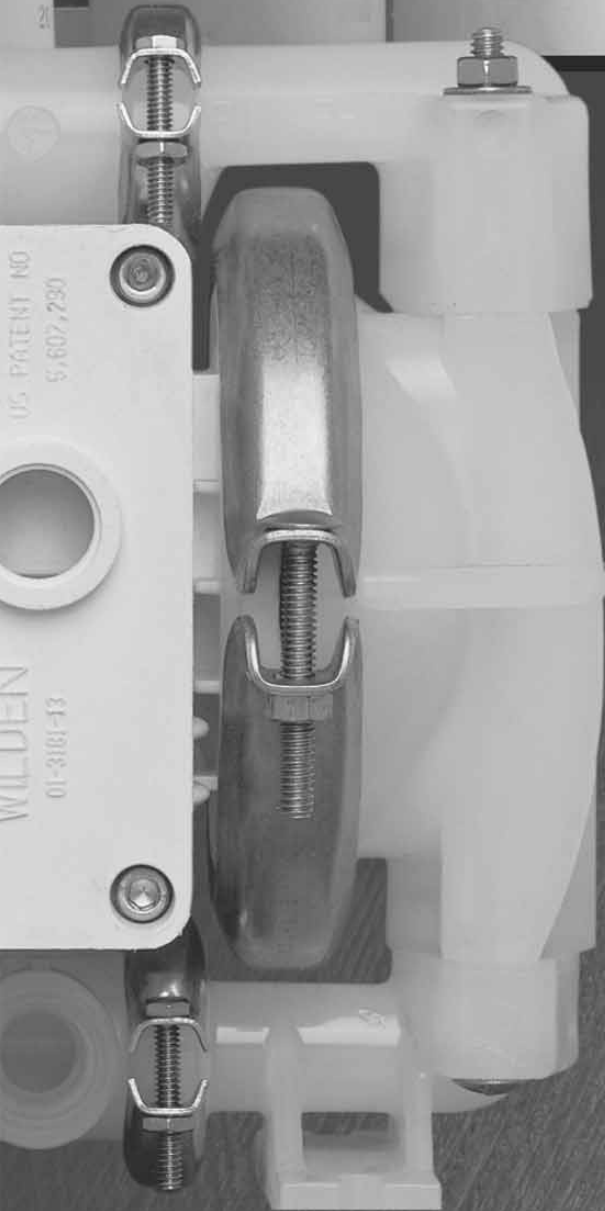

PROFLO[®]
PROGRESSIVE PUMP TECHNOLOGY

WILDEN[®]

A **DOVER** COMPANY

CE

WIL-10140-E-04
REPLACES WIL-10140-E-03

TABLE OF CONTENTS

SECTION 1 CAUTIONS—READ FIRST! 1

SECTION 2 WILDEN PUMP DESIGNATION SYSTEM 2

SECTION 3 HOW IT WORKS—PUMP & AIR DISTRIBUTION SYSTEM 3

SECTION 4 DIMENSIONAL DRAWINGS 4

SECTION 5 PERFORMANCE

 A. P1 Plastic - Rubber-Fitted 5

 P1 Plastic -TPE-Fitted..... 5

 P1 Plastic - PTFE-Fitted 6

 B. Suction Lift Curves 6

SECTION 6 SUGGESTED INSTALLATION, OPERATION & TROUBLESHOOTING 7

SECTION 7 ASSEMBLY / DISASSEMBLY 10

SECTION 8 EXPLODED VIEW & PARTS LISTING

 P1 Plastic

 Rubber-Fitted 20

 PTFE-Fitted 22

SECTION 9 ELASTOMER OPTIONS 24

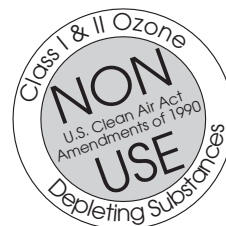

CAUTIONS—READ FIRST!

TEMPERATURE LIMITS:

Polypropylene	0°C to 79°C	32°F to 175°F
PVDF	-12°C to 107°C	10°F to 225°F
PTFE PFA	-28.9°C to 148.9°C	-20°F to 300°F
Neoprene	-17.8°C to 93.3°C	0°F to 200°F
Buna-N	-12.2°C to 82.2°C	10°F to 180°F
EPDM	-51.1°C to 137.8°C	-60°F to 280°F
Viton®	-40°C to 176.7°C	-40°F to 350°F
Wil-Flex™	-40°C to 107.2°C	-40°F to 225°F
Polyurethane	12.2°C to 65.6°C	10°F to 150°F
Saniflex™	-28.9°C to 104.4°C	-20°F to 220°F
PTFE	4.4°C to 104.4°C	40°F to 220°F



CAUTION: When choosing pump materials, be sure to check the temperature limits for all wetted components. Example: Viton® has a maximum limit of 176.7°C (350°F) but polypropylene has a maximum limit of only 79°C (175°F).



CAUTION: Maximum temperature limits are based upon mechanical stress only. Certain chemicals will significantly reduce maximum safe operating temperatures. Consult engineering guide for chemical compatibility and temperature limits.



CAUTION: Always wear safety glasses when operating pump. If diaphragm rupture occurs, material being pumped may be forced out air exhaust.



WARNING: Prevention of static sparking — If static sparking occurs, fire or explosion could result. Pump, valves, and containers must be properly grounded when handling flammable fluids and whenever discharge of static electricity is a hazard.



CAUTION: Do not exceed 8.6 bar (125 psig) air supply pressure.



CAUTION: Plastic series pumps are made of virgin plastic and are not UV stabilized. Direct sunlight for prolonged periods can cause deterioration of plastics.



CAUTION: Before any maintenance or repair is attempted, the compressed air line to the pump should be disconnected and all air pressure allowed to bleed from pump. Disconnect all intake, discharge and air lines. Drain the pump by turning it upside down and allowing any fluid to flow into a suitable container.



CAUTION: Blow out air line for 10 to 20 seconds before attaching to pump to make sure all pipe line debris is clear. Use an in-line air filter. A 5µ (micron) air filter is recommended.



NOTE: Tighten clamp bands prior to installation. Fittings may loosen during transportation.



NOTE: When installing PTFE diaphragms, it is important to tighten outer pistons simultaneously (turning in opposite directions) to ensure tight fit.



NOTE: Before starting disassembly, mark a line from each liquid chamber to its corresponding air chamber. This line will assist in proper alignment during reassembly.



CAUTION: Verify the chemical compatibility of the process and cleaning fluid to the pump's component materials in the Chemical Resistance Guide (see E4).



CAUTION: Only explosion proof (NEMA 7) solenoid valves should be used in areas where explosion proof equipment is required.



NOTE: Non lube-free pumps must be lubricated. Wilden suggests an arctic 5 weight oil (ISO grade 15). Do not over-lubricate air supply. Over-lubrication will reduce pump performance.



NOTE: P1 Plastic PTFE-fitted pumps come standard from the factory with expanded PTFE gaskets. (See Gasket Kit Installation in Section 8E.)



CAUTION: Do not over-tighten the air valve bolts. Too much torque on the air valve bolts may damage the air valve muffler plate. Do not exceed 3.3 N•m (29 in-lbs).



WILDEN PUMP DESIGNATION SYSTEM

**P1 ORIGINAL™
PLASTIC**

13 mm (1/2") Pump
Maximum Flow Rate:
56.8 lpm (15.0 gpm)

LEGEND

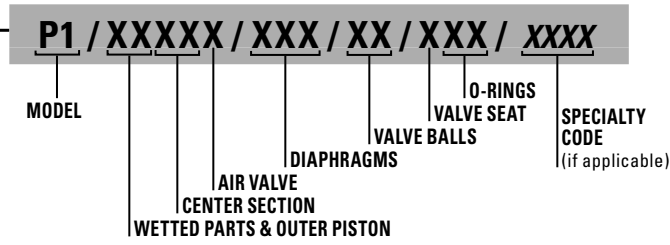

MATERIAL CODES

WETTED PARTS & OUTER PISTON

- KK = PVDF / PVDF
- KZ = PVDF / NO PISTON
- PP = POLYPROPYLENE / POLYPROPYLENE
- TT = PFA / PFA
- TZ = PTFE / NO PISTON

CENTER SECTION

- LL = ACETAL
- PP = POLYPROPYLENE

AIR VALVE

- P = POLYPROPYLENE

DIAPHRAGMS

- BNS = BUNA-N (Red Dot)
- FSS = SANIFLEX™ [Hytrel® (Cream)]
- PUS = POLYURETHANE (Clear)
- THU = PTFE W/HIGH-TEMP BUNA-N BACK-UP
- TEU = PTFE W/EPDM BACK-UP (White)
- TNU = PTFE W/NEOPRENE BACK-UP (White)
- TNL = PTFE W/NEOPRENE BACK-UP O-RING, IPD (White)
- VTS = VITON® (White Dot)
- WFS = WIL-FLEX™ [Santoprene® (Orange Dot)]

VALVE BALL

- BN = BUNA-N (Red Dot)
- FS = SANIFLEX™ [Hytrel® (Cream)]
- PU = POLYURETHANE (Brown)
- TF = PTFE (White)
- VT = VITON® (White Dot)
- WF = WIL-FLEX™ [Santoprene® (OrangeDot)]

VALVE SEAT

- K = PVDF
- P = POLYPROPYLENE

VALVE SEAT O-RING

- BN = BUNA-N
- FS = SANIFLEX™ [Hytrel® (Cream)]
- PU = POLYURETHANE (Brown)
- TV = PTFE ENCAP. VITON®
- WF = WIL-FLEX™ [Santoprene®]

SPECIALTY CODES

- | | | |
|---|--|--|
| 0100 Wil-Gard II™ 110V | 0525 Ultrapure II, female connections, PFA coated hardware, Wil-Gard II™ sensor wires ONLY | 0603 PFA coated hardware, Wil-Gard II™ 110V |
| 0102 Wil-Gard II™ sensor wires ONLY | 0530 Ultrapure II, Wil-Gard II™ 110V, female connections | 0608 PFA coated hardware, Wil-Gard II™ 220V |
| 0103 Wil-Gard II™ 220V | 0531 Ultrapure II, female connections, Wil-Gard II™ sensor wires ONLY | 0612 Ultrapure, PFA coated hardware, male connections |
| 0206 PFA coated hardware, Wil-Gard II™ sensor wires ONLY | 0532 Ultrapure II, PFA coated hardware, Wil-Gard II™ 110V, male bondable connections | 0618 Ultrapure, PFA coated hardware, Wil-Gard II™ 110V, male connections |
| 0502 PFA coated hardware | 0533 Ultrapure II, PFA coated hardware, Wil-Gard II™ 220V, male bondable connections | 0622 Ultrapure, male connections |
| 0520 Ultrapure II, female connections | 0560 Split manifold | 0623 Ultrapure, adapter block, no muffler, male connections |
| 0521 Ultrapure II, PFA coated hardware, female connections | 0561 Split manifold, PFA coated hardware | 0624 Ultrapure, Wil-Gard II™ 110V, male connections |
| 0522 Ultrapure II, male bondable connections | 0563 Split manifold, discharge only | 0660 Split manifold, Wil-Gard II™ 110V |
| 0523 Ultrapure II, PFA coated hardware, male bondable connections | 0564 Split manifold, Inlet ONLY | 0661 Split manifold, PFA coated hardware, Wil-Gard II™ 110V |
| 0524 Ultrapure II, Wil-Gard II™ 110V, male bondable connections | | |

NOTE: MOST ELASTOMERIC MATERIALS USE COLORED DOTS FOR IDENTIFICATION.

Viton® is registered trademarks of DuPont Dow Elastomers.

HOW IT WORKS—PUMP

The Wilden diaphragm pump is an air-operated, positive displacement, self-priming pump. These drawings show the flow pattern through the pump upon its initial stroke. It is assumed the pump has no fluid in it prior to its initial stroke.

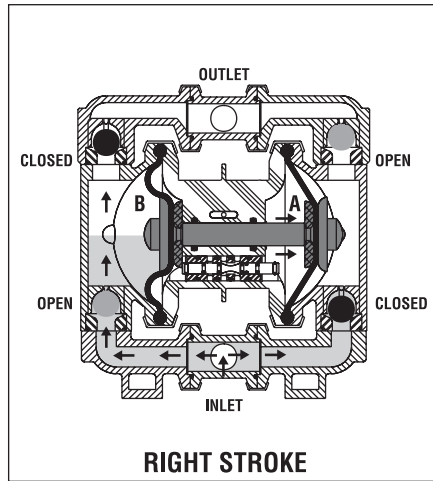

RIGHT STROKE

FIGURE 1 The air valve directs pressurized air to the back side of diaphragm A. The compressed air is applied directly to the liquid column separated by elastomeric diaphragms. The diaphragm acts as a separation membrane between the compressed air and liquid, balancing the load and removing mechanical stress from the diaphragm. The compressed air moves the diaphragm away from the center block of the pump. The opposite diaphragm is pulled in by the shaft connected to the pressurized diaphragm. Diaphragm B is on its suction stroke; air behind the diaphragm has been forced out to the atmosphere through the exhaust port of the pump. The movement of diaphragm B toward the center block of the pump creates a vacuum within chamber B. Atmospheric pressure forces fluid into the inlet manifold forcing the inlet valve ball off its seat. Liquid is free to move past the inlet valve ball and fill the liquid chamber (see shaded area).

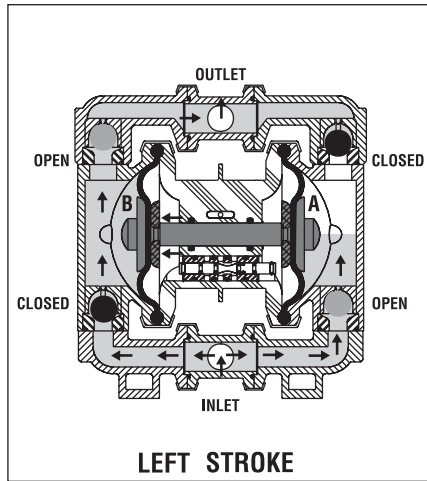

LEFT STROKE

FIGURE 2 When the pressurized diaphragm, diaphragm A, reaches the limit of its discharge stroke, the air valve redirects pressurized air to the back side of diaphragm B. The pressurized air forces diaphragm B away from the center block while pulling diaphragm A to the center block. Diaphragm B is now on its discharge stroke. Diaphragm B forces the inlet valve ball onto its seat due to the hydraulic forces developed in the liquid chamber and manifold of the pump. These same hydraulic forces lift the discharge valve ball off its seat, while the opposite discharge valve ball is forced onto its seat, forcing fluid to flow through the pump discharge. The movement of diaphragm A toward the center block of the pump creates a vacuum within liquid chamber A. Atmospheric pressure forces fluid into the inlet manifold of the pump. The inlet valve ball is forced off its seat allowing the fluid being pumped to fill the liquid chamber.

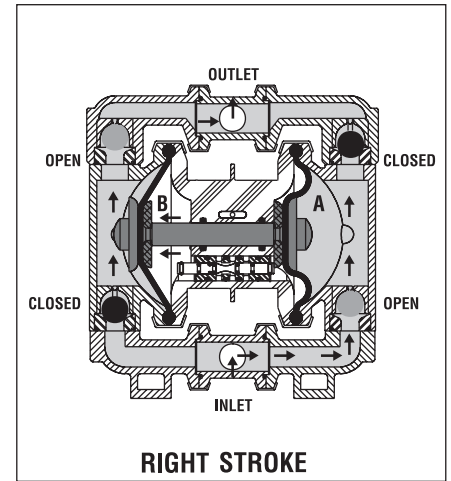

RIGHT STROKE

FIGURE 3 At completion of the stroke, the air valve again redirects air to the back side of diaphragm A, which starts diaphragm B on its exhaust stroke. As the pump reaches its original starting point, each diaphragm has gone through one exhaust and one discharge stroke. This constitutes one complete pumping cycle. The pump may take several cycles to completely prime depending on the conditions of the application.

HOW IT WORKS—AIR DISTRIBUTION SYSTEM

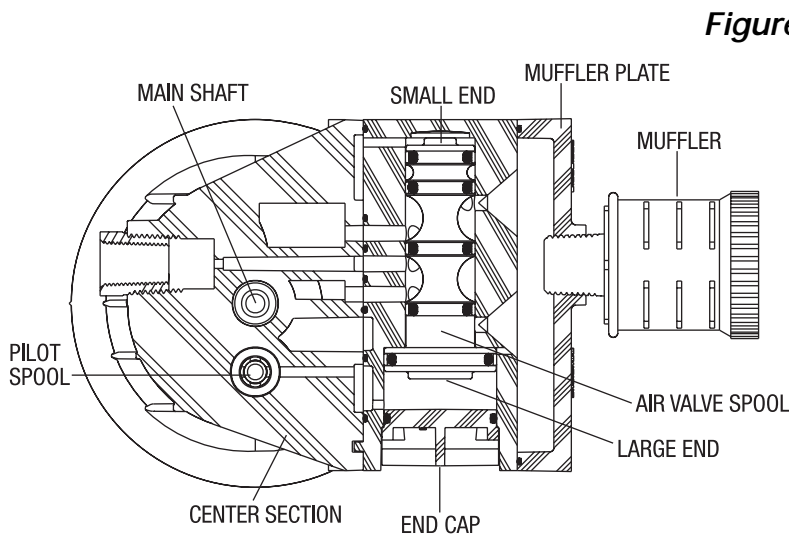

Figure A

The Pro-Flo® patented air distribution system incorporates three moving parts: the air valve spool, the pilot spool, and the main shaft/diaphragm assembly. The heart of the system is the air valve spool and air valve. As shown in Figure A, this valve design incorporates an unbalanced spool. The smaller end of the spool is pressurized continuously, while the large end is alternately pressurized then exhausted to move the spool. The spool directs pressurized air to one air chamber while exhausting the other. The air causes the main shaft/diaphragm assembly to shift to one side — discharging liquid on that side and pulling liquid in on the other side. When the shaft reaches the end of its stroke, the inner piston actuates the pilot spool, which pressurizes and exhausts the large end of the air valve spool. The repositioning of the air valve spool routes the air to the other air chamber.

DIMENSIONAL DRAWINGS

DIMENSIONS

ITEM	METRIC (mm)	STANDARD (inch)
A	31	1.2
B	130	5.1
C	196	7.7
D	208	8.2
E	218	8.6
F	56	2.2
G	114	4.5
H	127	5.0
J	203	8.0
K	145	5.7
L	114	4.5
M	84	3.3
N	102	4.0
P	8	0.3
R	20	0.8
S	28	1.1

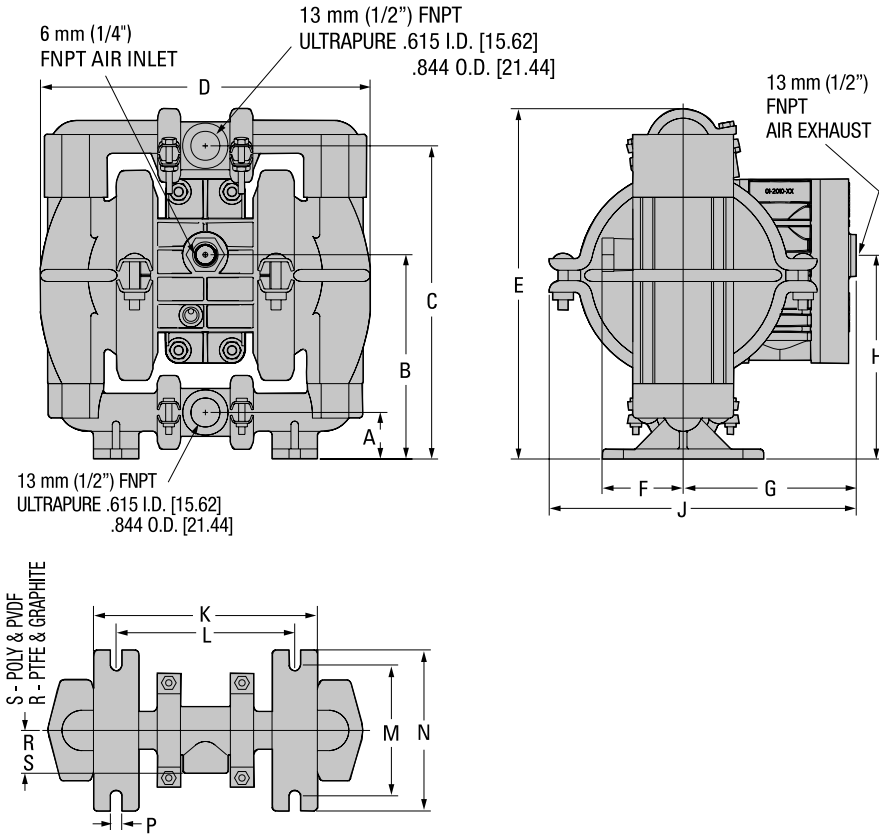

**P1 PLASTIC
PTFE-FITTED**

Height.....218 mm (8.6")
 Width.....208 mm (8.2")
 Depth.....203 mm (8.0")
 Est. Ship Weight..... Polypropylene 4 kg (9 lbs)
 PVDF 5 kg (11 lbs)
 PTFE PFA 6 kg (12 lbs)
 Air Inlet..... 6 mm (1/4")
 Inlet..... 13 mm (1/2")
 Outlet..... 13 mm (1/2")
 Suction Lift.....5.18 m Dry (17')
 9.8 m Wet (32')

Displacement per Stroke0.10 l (0.027 gal.)¹
 Max. Flow Rate.....53.4 lpm (14.1 gpm)
 Max. Size Solids 1.6 mm (1/16")

¹Displacement per stroke was calculated at 4.8 bar (70 psig) air inlet pressure against a 2 bar (30 psig) head pressure.

Example: To pump 18.9 lpm (5 gpm) against a discharge pressure head of 2.8 bar (40 psig) requires 3.9 bar (56 psig) and 6.93 Nm³/h (4.1 scfm) air consumption. (See dot on chart.)

Caution: Do not exceed 8.6 bar (125 psig) air supply pressure.

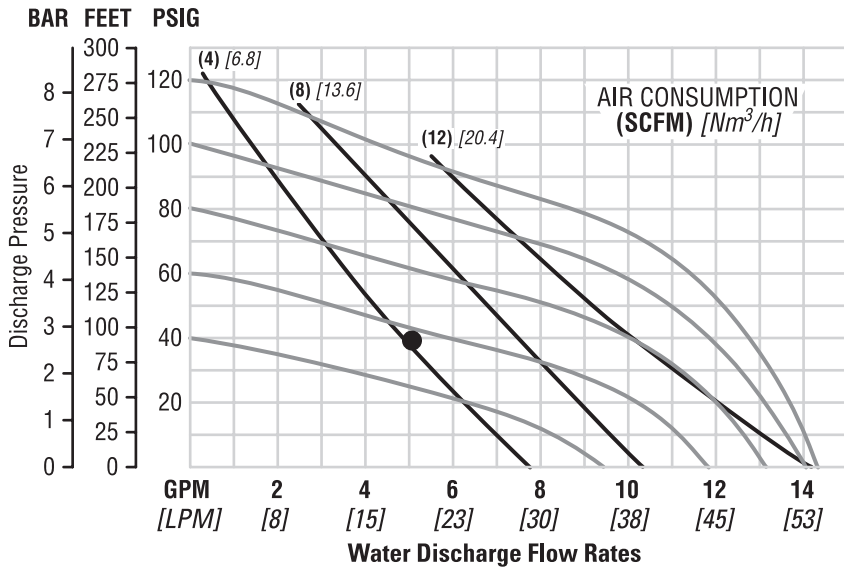

Flow rates indicated on chart were determined by pumping water.

For optimum life and performance, pumps should be specified so that daily operation parameters will fall in the center of the pump performance curve.

Section 5B SUCTION LIFT CURVE

**P1 PLASTIC
SUCTION LIFT CAPABILITY**

Suction lift curves are calibrated for pumps operating at 305 m (1,000') above sea level. This chart is meant to be a guide only. There are many variables which can affect your pump's operating characteristics. The number of intake and discharge elbows, viscosity of pumping fluid, elevation (atmospheric pressure) and pipe friction loss all affect the amount of suction lift your pump will attain.

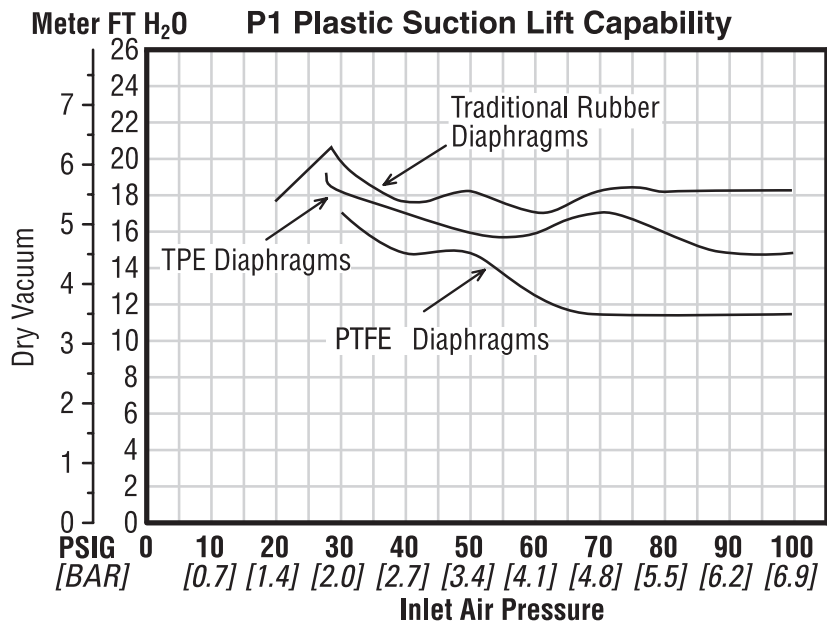

The Pro-Flo® model P1 has a 13 mm (1/2") inlet and 13 mm (1/2") outlet and is designed for flows to 56.8 lpm (15 gpm). The **P1 Plastic** pump is manufactured with wetted parts of pure, unpigmented PVDF, PTFE PFA or polypropylene. The **P1 Plastic** is constructed with a polypropylene center section. A variety of diaphragms and o-rings are available to satisfy temperature, chemical compatibility, abrasion and flex concerns.

The suction pipe size should be at least 13 mm (1/2") diameter or larger if highly viscous material is being pumped. The suction hose must be non-collapsible, reinforced type as the P1 is capable of pulling a high vacuum. Discharge piping should be at least 13 mm (1/2"); larger diameter can be used to reduce friction losses. It is critical that all fittings and connections are airtight or a reduction or loss of pump suction capability will result.

INSTALLATION: Months of careful planning, study, and selection efforts can result in unsatisfactory pump performance if installation details are left to chance.

Premature failure and long term dissatisfaction can be avoided if reasonable care is exercised throughout the installation process.

LOCATION: Noise, safety, and other logistical factors usually dictate where equipment be situated on the production floor. Multiple installations with conflicting requirements can result in congestion of utility areas, leaving few choices for additional pumps.

Within the framework of these and other existing conditions, every pump should be located in such a way that five key factors are balanced against each other to maximum advantage.

ACCESS: First of all, the location should be accessible. If it's easy to reach the pump, maintenance personnel will have an easier time carrying out routine inspections and adjustments. Should major repairs become necessary, ease of access can play a key role in speeding the repair process and reducing total downtime.

AIR SUPPLY: Every pump location should have an air line large enough to supply the volume of air necessary to achieve the desired pumping rate (see Section 5). Use air pressure up to a maximum of 8.6 bar (125 psig) depending on pumping requirements.

For best results, the pumps should use a 5µ micron air filter, needle valve and regulator. The use of an air filter before the pump will insure that the majority of any pipeline contaminants will be eliminated.

SOLENOID OPERATION: When operation is controlled by a solenoid valve in the air line, three-way valves should be used, thus allowing trapped air to bleed off and improving pump performance. Pumping volume can be set by counting the number of strokes per minute and multiplying by displacement per stroke.

Sound levels are reduced below OSHA specifications using the standard Wilden muffler element. Other mufflers can be used but usually reduce pump performance.

ELEVATION: Selecting a site that is well within the pump's dynamic lift capability will assure that loss-of-prime troubles will be eliminated. In addition, pump efficiency can be adversely affected if proper attention is not given to site location.

PIPING: Final determination of the pump site should not be made until the piping problems of each possible location have been evaluated. The impact of current and future installations should be considered ahead of time to make sure that inadvertent restrictions are not created for any remaining sites.

The best choice possible will be a site involving the shortest and straightest hook-up of suction and discharge piping. Unnecessary elbows, bends, and fittings should be avoided. Pipe sizes should be selected so as to keep friction losses within practical limits. All piping should be supported independently of the pump. In addition, the piping should be aligned so as to avoid placing stresses on the pump fittings.

Flexible hose can be installed to aid in absorbing the forces created by the natural reciprocating action of the pump. If the pump is to be bolted down to a solid location, a mounting pad placed between the pump and the foundation will assist in minimizing pump vibration. Flexible connections between the pump and rigid piping will also assist in minimizing pump vibration. If quick-closing valves are installed at any point in the discharge system, or if pulsation within a system becomes a problem, a surge suppressor should be installed to protect the pump, piping and gauges from surges and water hammer.

When pumps are installed in applications involving flooded suction or suction head pressures, a gate valve should be installed in the suction line to permit closing of the line for pump service.

For **P1 Plastic** models, a non-raised surfaced-flange adapter should be utilized when mating to the pump's inlet and discharge manifolds for proper sealing.

The P1 can be installed in submersible applications only when both the wetted and non-wetted portions are compatible with the material being pumped. If the pump is to be used in a submersible application, a hose should be attached to the pump's air and pilot spool exhaust ports and piped above the liquid level. The exhaust area for the pilot spool is designed to be tapped for a 1/8" NPT fitting.

If the pump is to be used in a self-priming application, be sure that all connections are airtight and that the suction lift is within the model's ability. Note: Materials of construction and elastomer material have an effect on suction lift parameters. Please consult Wilden distributors for specifics.

Pumps in service with a positive suction head are most efficient when inlet pressure is limited to 0.5–0.7 bar (7–10 psig). Premature diaphragm failure may occur if positive suction is 10 psig and higher.

THE MODEL P1 PLASTIC WILL PASS 1.6 MM (1/16") SOLIDS. WHENEVER THE POSSIBILITY EXISTS THAT LARGER SOLID OBJECTS MAY BE SUCKED INTO THE PUMP, A STRAINER SHOULD BE USED ON THE SUCTION LINE.

CAUTION: DO NOT EXCEED 8.6 BAR (125 PSIG) AIR SUPPLY PRESSURE.

SUGGESTED INSTALLATION

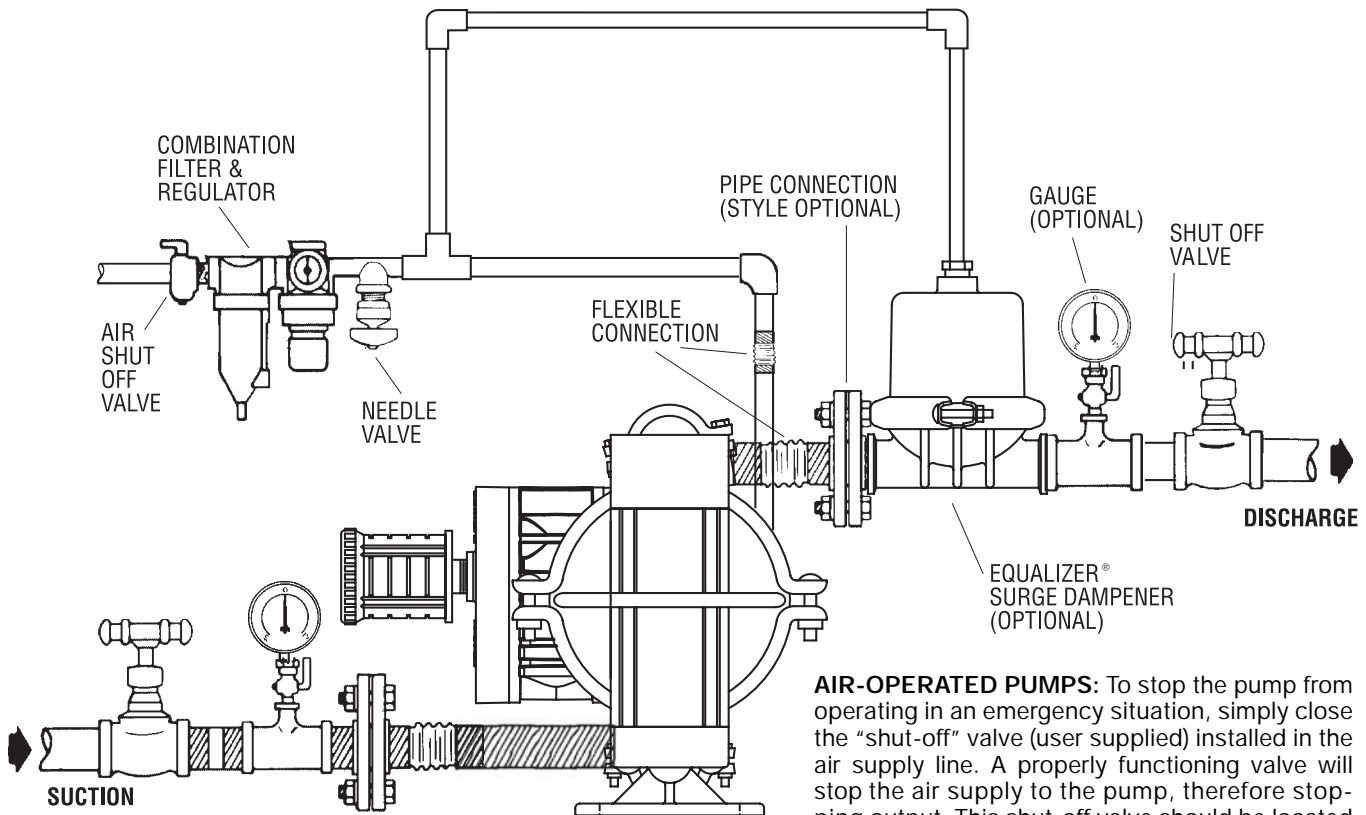

AIR-OPERATED PUMPS: To stop the pump from operating in an emergency situation, simply close the "shut-off" valve (user supplied) installed in the air supply line. A properly functioning valve will stop the air supply to the pump, therefore stopping output. This shut-off valve should be located far enough away from the pumping equipment such that it can be reached safely in an emergency situation.

NOTE: In the event of a power failure, the shutoff valve should be closed, if the restarting of the pump is not desirable once power is regained.

SUGGESTED OPERATION & MAINTENANCE

OPERATION: Pump discharge rate can be controlled by limiting the volume and/or pressure of the air supply to the pump (preferred method). An air regulator is used to regulate air pressure. A needle valve is used to regulate volume. Pump discharge rate can also be controlled by throttling the pump discharge by partially closing a valve in the discharge line of the pump. This action increases friction loss which reduces flow rate. This is useful when the need exists to control the pump from a remote location. When the pump discharge pressure equals or exceeds the air supply pressure, the pump will stop; no bypass or pressure relief valve is needed, and pump damage will not occur. The pump has reached a "deadhead" situation and can be restarted by reducing the fluid discharge pressure or increasing the air inlet pressure. The Wilden P1 pump runs solely on compressed air and does not generate heat, therefore your process fluid temperature will not be affected.

RECORDS: When service is required, a record should be made of all necessary repairs and replacements. Over a period of time, such records can become a valuable tool for predicting and preventing future maintenance problems and unscheduled downtime. In addition, accurate records make it possible to identify pumps that are poorly suited to their applications.

MAINTENANCE AND INSPECTIONS: Since each application is unique, maintenance schedules may be different for every pump. Frequency of use, line pressure, viscosity and abrasiveness of process fluid all affect the parts life of a Wilden pump. Periodic inspections have been found to offer the best means for preventing unscheduled pump downtime. Personnel familiar with the pump's construction and service should be informed of any abnormalities that are detected during operation.

Pump will not run or runs slowly.

1. Ensure that the air inlet pressure is at least 0.4 bar (5 psig) above startup pressure and that the differential pressure (the difference between air inlet and liquid discharge pressures) is not less than 0.7 bar (10 psig).
2. Check air inlet filter for debris (see recommended installation).
3. Check for extreme air leakage (blow by) which would indicate worn seals/bores in the air valve, pilot spool and main shaft.
4. Disassemble pump and check for obstructions in the air passageways or objects which would obstruct the movement of internal parts.
5. Check for sticking ball check valves. If material being pumped is not compatible with pump elastomers, swelling may occur. Replace ball check valves and seals with proper elastomers. Also, as the check valve balls wear out, they become smaller and can become stuck in the seats. In this case, replace balls and seats.
6. Check for broken inner piston which will cause the air valve spool to be unable to shift.
7. Remove plug from pilot spool exhaust.

Pump runs but little or no product flows.

1. Check for pump cavitation; slow pump speed down to allow thick material to flow into the liquid chambers.

2. Verify that vacuum required to lift liquid is not greater than the vapor pressure of the material being pumped (cavitation).
3. Check for sticking ball check valves. If material being pumped is not compatible with pump elastomers, swelling may occur. Replace ball check valves and seals with proper elastomers. Also, as the check valve balls wear out, they become smaller and can become stuck in the seats. In this case, replace balls and seats.

Pump air valve freezes.

1. Check for excessive moisture in compressed air. Either install a dryer or hot air generator for compressed air. Alternatively, a coalescing filter may be used to remove the water from the compressed air in some applications.

Air bubbles in pump discharge.

1. Check for ruptured diaphragm.
2. Check tightness of outer pistons. (Refer to Section 8C.)
3. Check tightness of clamp bands and integrity of o-rings and seals, especially at intake manifold.
4. Ensure pipe connections are airtight.

Product comes out air exhaust.

1. Check for diaphragm rupture.
2. Check tightness of outer pistons to shaft.

CAUTION: Before any maintenance or repair is attempted, the compressed air line to the pump should be disconnected and all air pressure allowed to bleed from the pump. Disconnect all intake, discharge, and air lines. Drain the pump by turning it upside down and allowing any fluid to flow into a suitable container. Be aware of any hazardous effects of contact with your process fluid.

The Wilden model P1 has a 13 mm (1/2") inlet and outlet and is designed for flows up to 56.8 lpm (15 gpm). The single-piece center block, consisting of center block and air chambers, is molded of polypropylene or acetal. All fasteners and hardware are stainless steel and the air valve is manufactured of brass or high-tech engineered thermoplastic. Its air distribution system is based on a revolutionary design, which offers economical reliability and performance. The model P1 Plastic is available in injection-molded polypropylene, PVDF and PTFE PFA wetted parts.

TOOLS REQUIRED:

8 mm (5/16") Wrench
 5 mm (3/16") Allen Wrench
 10 mm (3/8") Wrench
 11 mm (7/16") Wrench
 Adjustable Wrench
 Vise equipped with soft jaws (such as plywood, plastic or other suitable material)

NOTE: The model used for these instructions incorporates rubber diaphragms, balls, and seats. Models with PTFE diaphragms, balls and seats are the same except where noted.

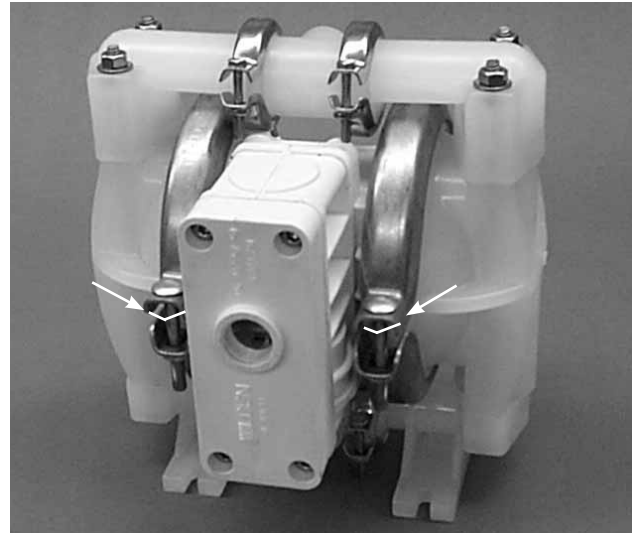

DISASSEMBLY:

Figure 1

Step 1.

Before starting disassembly, mark a line from each liquid chamber to its corresponding air chamber. This line will assist in proper alignment during reassembly.

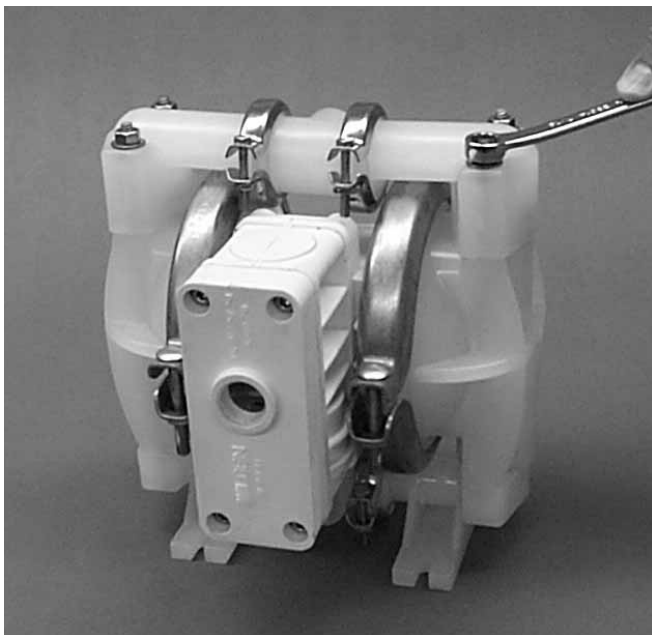

Step 2.

Figure 2

Utilizing the 10 mm (3/8") box wrench, start by removing the four long carriage bolts that hold the top and bottom manifolds to the center section.

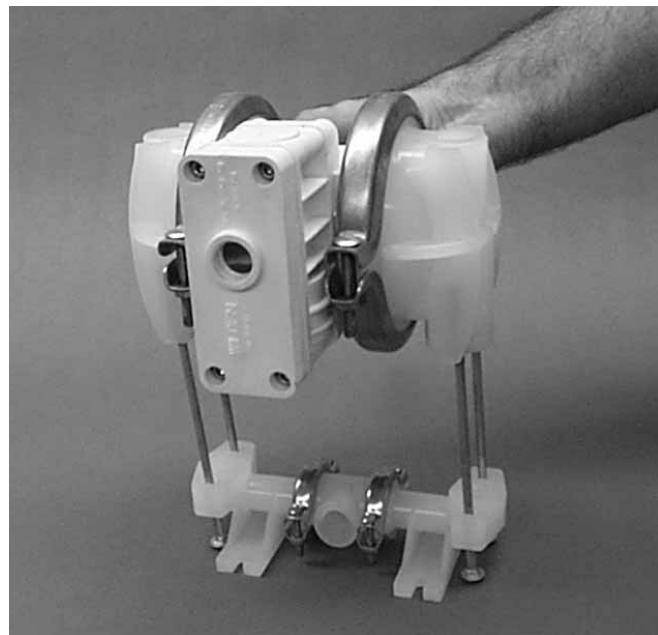

Step 3.

Figure 3

Remove the top manifold and lift the center section off the inlet manifold.

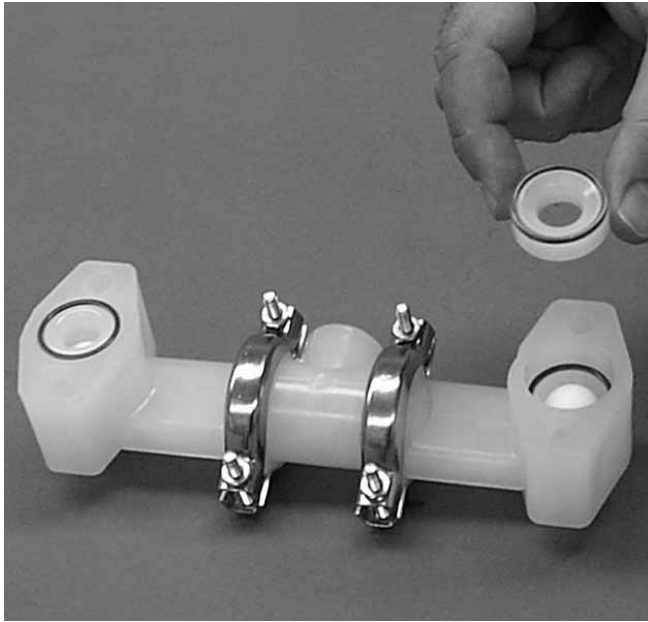

Step 4. *Figure 4*
Remove the discharge valve balls, seats and o-rings from the discharge manifold and inspect for nicks, gouges, chemical attack or abrasive wear. Replace worn parts with genuine Wilden parts for reliable performance. PTFE o-rings should be replaced when reassembled.

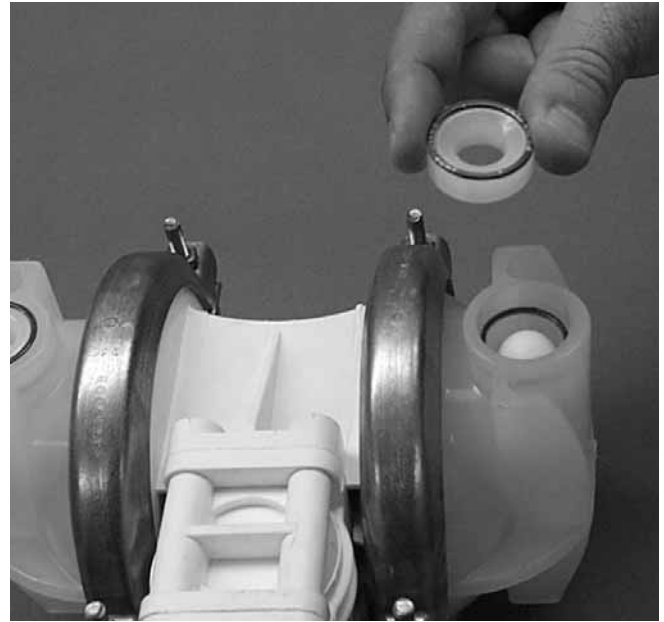

Step 5. *Figure 5*
Remove and inspect the ball retainer, retainer o-ring, and valve ball from the bottom of the liquid chamber. Check for nicks, gouges, chemical attack or abrasive wear. Replace worn parts with genuine Wilden parts for reliable performance. PTFE o-rings should be replaced when reassembled.

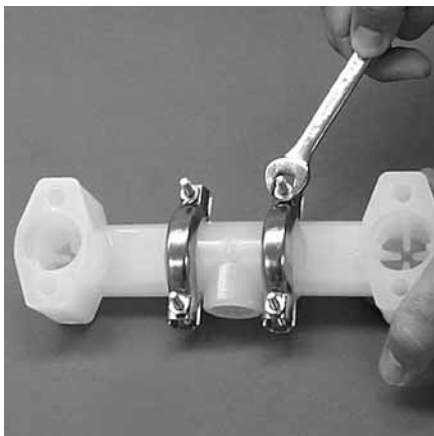

Step 6. *Figure 6*
Normally the inlet and discharge manifold should not be disassembled during regular pump maintenance. Should this be necessary completely remove and disassemble manifold clamp bands.



Step 7. *Figure 7*
Inspect o-rings for wear or damage and replace if necessary. PTFE o-rings should be replaced when reassembled.

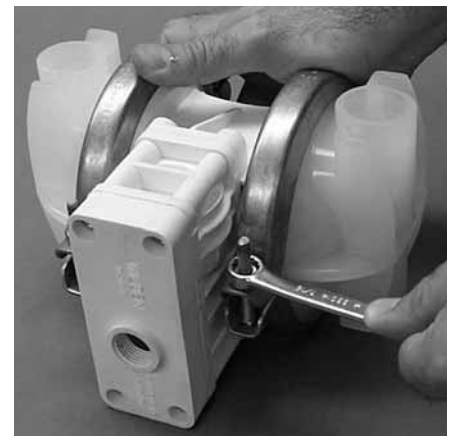

Step 8. *Figure 8*
Use a 11 mm (7/16") wrench to remove one set of clamp bands that secure one liquid chamber to the one-piece center section.

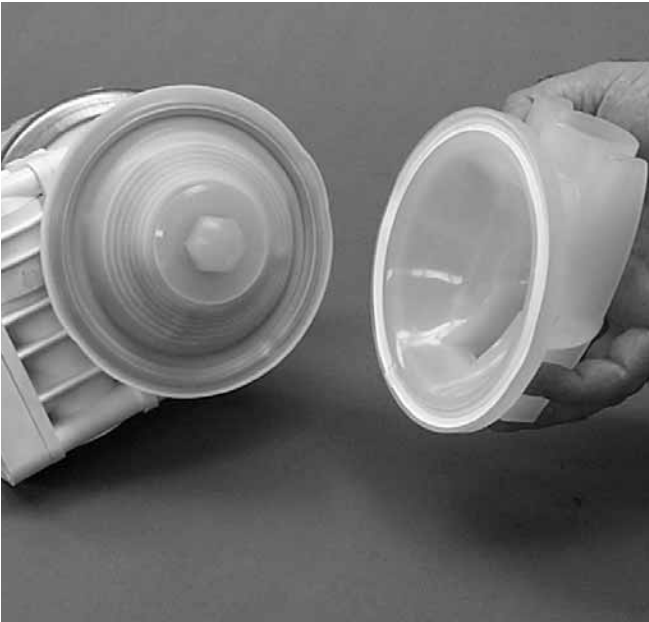

Step 9. *Figure 9*
Lift the liquid chamber away from the center section to expose the diaphragm and outer piston.



Step 10. *Figure 10*
Using an adjustable wrench, or by rotating the diaphragm by hand, remove the diaphragm assembly from the center section.



Step 11A. *Figure 11A*

NOTE: Due to varying torque values, one of the following two situations may occur: 1) The outer piston, diaphragm and inner piston remain attached to the shaft and the entire assembly can be removed from the center section.



Step 11B. *Figure 11B*

2) The outer piston, diaphragm, inner piston, and disc spring separate from the shaft which remains connected to the opposite side diaphragm assembly. PTFE-fitted pumps come standard with back-up diaphragms (not shown).

NOTE: Disc spring not shown on *Figure 11B*.

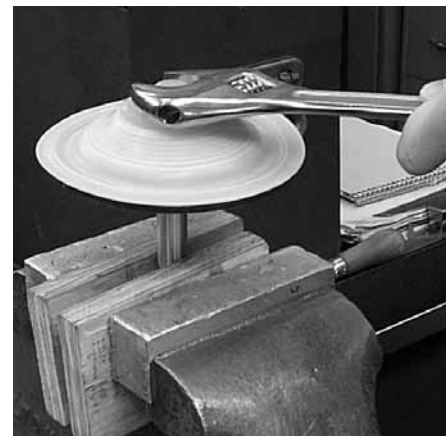

Step 12. *Figure 12*

To remove the diaphragm assembly from the shaft, secure shaft with soft jaws (a vise fitted with plywood or other suitable material) to ensure shaft is not nicked, scratched, or gouged. Using an adjustable wrench, remove diaphragm assembly from shaft. Inspect all parts for wear and replace with genuine Wilden parts if necessary.

SINGLE-PIECE MANIFOLD DISASSEMBLY/REASSEMBLY

CAUTION: Before any maintenance or repair is attempted, the compressed air line to the pump should be disconnected and all air pressure allowed to bleed from pump. Disconnect all intake, discharge, and air lines. Drain the pump by turning it upside down and allowing any fluid to flow into a suitable container.

The Wilden single-piece manifold pump models are air-operated, double-diaphragm pumps with all wetted parts molded in PTFE PFA. The single-piece center section, consisting of center block and air chambers, is molded from glass-filled acetal on conductive models. All fasteners and hardware are stainless steel. The primary diaphragm is constructed of PTFE. All wetted sealing o-rings are PTFE encapsulated Viton® on the UPII. The standard air distribution system is used on the UPII. All o-rings used in the pump are of a special material, and should only be replaced with Wilden factory-supplied parts.

Tools required to perform maintenance on the Model P1 pump are: 3/16-inch, 5/16-inch and 9/16-inch Allen wrench, 7/16-inch wrench, two open end adjustable wrenches, and an o-ring pick.

PLEASE read all directions before starting disassembly.

DISASSEMBLY:

Before actual disassembly is started, turn pump upside down and drain all liquid trapped in the pump into a suitable container. Be sure to use proper caution if liquid is corrosive or toxic. Mark each liquid chamber to its respective air chamber for easy alignment during reassembly.

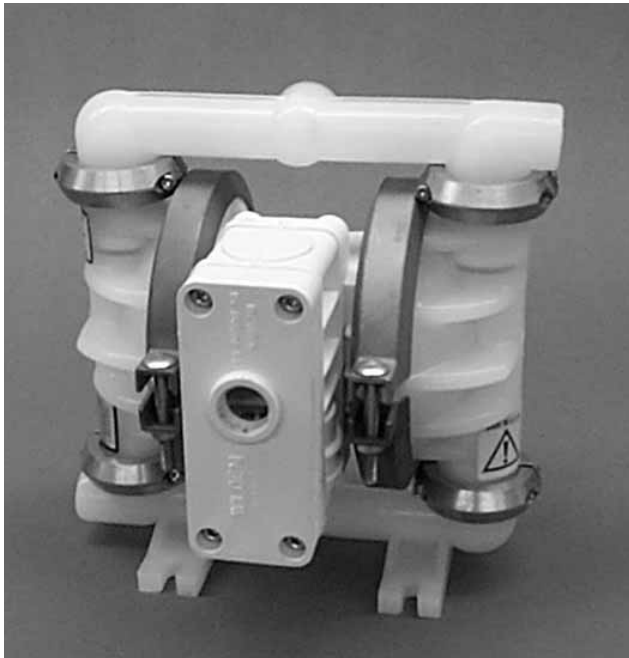

P1 PTFE PFA Construction

SINGLE-PIECE MANIFOLD DISASSEMBLY/REASSEMBLY

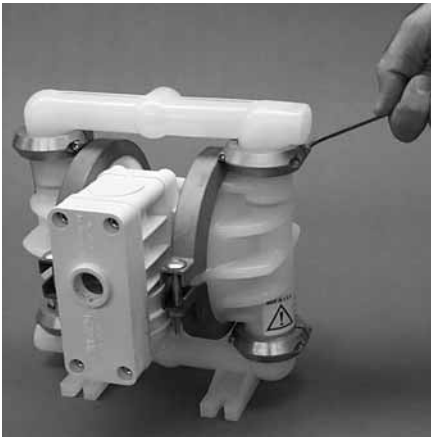

Step 1. *Figure 1*

Using an appropriate sized Allen wrench, remove clamp bands that hold the discharge manifold to the water chambers.



Step 2. *Figure 2*

Remove discharge manifold. It is now possible to inspect the outboard o-rings.



Step 3. *Figure 3*

Remove the o-ring, ball cage and ball valve from the water chamber. It is now possible to inspect these parts. Using the o-ring pick, remove the seat and seat o-ring from the water chamber for further inspection. If swelling, cracking or other damage is apparent, these parts must be replaced.

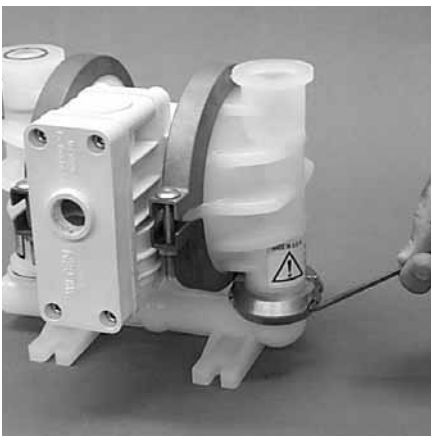

Step 4. *Figure 4*

Loosen and remove clamp bands from around the inlet manifold.

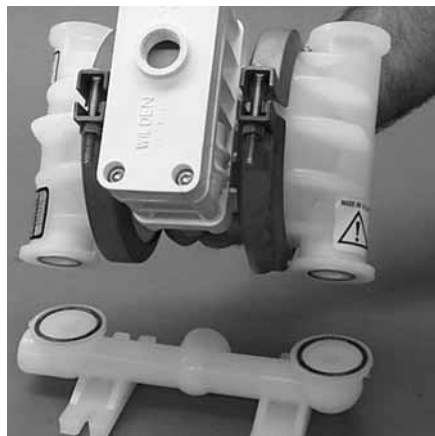

Step 5. *Figure 5*

Lift center section off of the inlet manifold. It is now possible to inspect the outboard o-rings on the inlet manifold.



Step 6. *Figure 6*

Place center section upside-down on a flat surface. Remove the o-ring, seat and valve ball from the bottom of the water chamber. It is now possible to inspect these parts. If swelling, cracking or other damage is apparent these parts must be replaced.

AIR VALVE / CENTER BLOCK DISASSEMBLY

AIR VALVE DISASSEMBLY:

CAUTION: Before any maintenance or repair is attempted, the compressed air line to the pump should be disconnected and all air pressure allowed to bleed from the pump. Disconnect all intake, discharge, and air lines. Drain the pump by turning it upside down and allowing any fluid to flow into a suitable container. Be aware of hazardous effects of contact with your process fluid.

The Wilden Plastic P1 utilizes a revolutionary Pro-Flo® air distribution system. A 13 mm (1/2") air inlet connects the air supply to the center section. Proprietary composite seals reduce the coefficient of friction and allow the P1 to run lube-free. Constructed of acetal or polypropylene, the Pro-Flo® air distribution system is designed to perform in on/off, non-freezing, non-stalling, tough duty applications.

TOOLS REQUIRED:

- 3/16" Hex Head Wrench
- 7/32" Hex Head Wrench
- Snap Ring Pliers
- O-Ring Pick

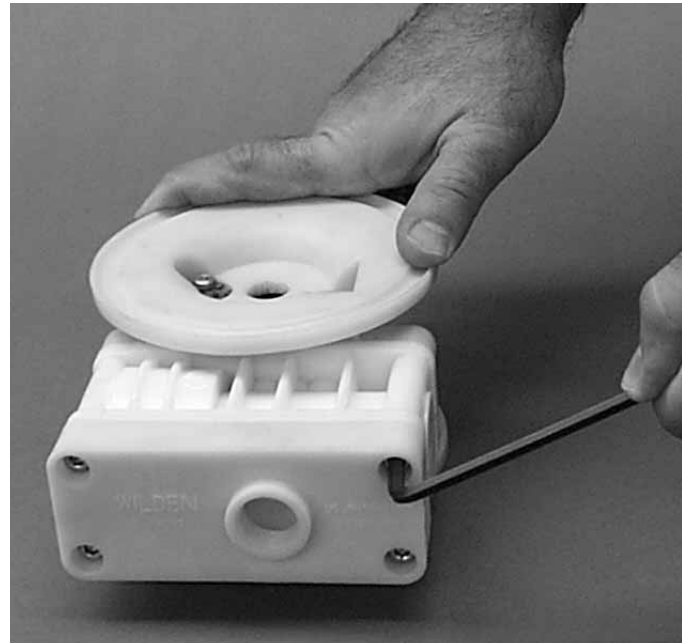

Step 1.

Figure 1

Loosen the air valve bolts utilizing a 3/16" hex head wrench.



Step 2.

Figure 2

Remove muffer plate and air valve bolts from air valve assembly exposing muffer gasket for inspection. Replace if necessary.



Step 3.

Figure 3

Lift away air valve assembly and remove air valve gasket for inspection. Replace if necessary.



Step 4.

Figure 4

Remove air valve end cap to expose air valve spool by simply lifting up on end cap once air valve bolts are removed.

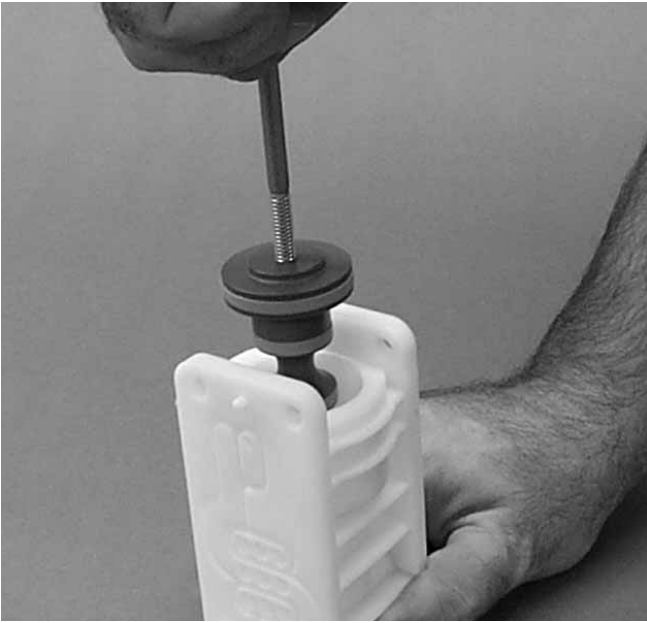

Step 5. *Figure 5*

Remove air valve spool from air valve body by threading one air valve bolt into the end of the spool and gently sliding the spool out of the air valve body. Inspect seals for signs of wear and replace entire assembly if necessary. Use caution when handling air valve spool to prevent damaging seals.

NOTE: Seals should not be removed from assembly. Seals are not sold separately.



Step 6. *Figure 6*

Remove pilot spool sleeve retaining snap ring on both sides of center section with snap ring pliers.



Step 7. *Figure 7*

Remove pilot spool sleeve from center section.



Step 8. *Figure 8*

With o-ring pick, gently remove the o-ring from the opposite side of the "center hole" cut on the spool. Gently remove the pilot spool from sleeve and inspect for nicks or gouges and other signs of wear. Replace pilot sleeve assembly or outer sleeve o-rings if necessary. During re-assembly never insert the pilot spool into the sleeve with the "center cut" side first, this end incorporates the urethane o-ring and will be damaged as it slides over the ports cut in the sleeve.

NOTE: Seals should not be removed from pilot spool. Seals are not sold separately.



Step 9. *Figure 9*

Check center section Glyd™ rings for signs of wear. If necessary, remove Glyd™ rings with o-ring pick and replace.

ASSEMBLY:

Upon performing applicable maintenance to the air distribution system, the pump can now be reassembled. Please refer to the disassembly instructions for photos and parts placement. To reassemble the pump, follow the disassembly instructions in reverse order. The air distribution system needs to be assembled first, then the diaphragms and finally the wetted path. Please find the applicable torque specifications on this page. The following tips will assist in the assembly process.

- Clean the inside of the center section shaft bore to ensure no damage is done to new seals.
- Stainless bolts should be lubed to reduce the possibility of seizing during tightening.
- Level the water chamber side of the intake/discharge manifold to ensure a proper sealing surface. This is most easily accomplished by placing them on a flat surface prior to tightening their clamp bands to the desired torque (see this page for torque specs).
- Be sure to tighten outer pistons simultaneously on PTFE-fitted pumps to ensure proper torque values.
- Ensure proper mating of liquid chambers to manifolds prior to tightening vertical bolts. Overhang should be equal on both sides.
- Apply a small amount of Loctite 242 to the shaft interval threads before the diaphragm assembly.
- Concave side of disc spring in diaphragm assembly faces **toward** shaft.

MAXIMUM TORQUE SPECIFICATIONS

Description of Part	Plastic Pumps
Air Valve, Pro-Flo [®]	3.1 N•m (27 in-lbs)
Outer Piston	14.1 N•m (125 in-lbs)
Small Clamp Band	1.7 N•m (15 in-lbs)
Large Clamp Band (Rubber-Fitted)	7.3 N•m (65 in-lbs)
Large Clamp Band (PTFE-Fitted)	9.6 N•m (85 in-lbs)
Vertical Bolts (Rubber Fitted) PVDF	5.6 N•m (50 in-lbs)
Vertical Bolts (PTFE Fitted) PVDF, PFA	2.8 N•m (25 in-lbs)
Vertical Bolts, all Polypropylene	9.0 N•m (80 in-lbs)

P1 PVDF and Ultrapure pumps come standard with expanded PTFE Gasket Kits (P/N 01-9501-99) for all sealing surfaces. P1 Poly pumps come standard with expanded PTFE Gasket Kits (P/N 01-9500-99) for diaphragm bead only. Carefully prepare sealing surfaces by removing all debris and foreign

matter from diaphragm bead and all mating surfaces. If necessary, smooth or deburr all sealing surfaces. Mating surfaces must be properly aligned in order to ensure positive sealing characteristics.

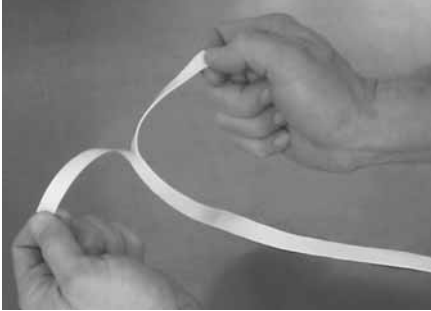

Step 1. *Figure 1*

Gently remove the adhesive covering from the back of the PTFE tape. Ensure that the adhesive strip remains attached to the PTFE tape and is not removed with the adhesive covering.



Step 2. *Figure 2*

Starting at any point, place the PTFE tape directly on top of the diaphragm bead. Press lightly on the tape to ensure that the adhesive holds it in place during assembly. Do not stretch the tape during placement on the diaphragm bead.



Step 3. *Figure 3*

The end of the tape should overlap approximately 13 mm (1/2"). Proceed to install the PTFE tape on the remaining diaphragm.



Step 4. *Figure 4*

Carefully remove the protective covering from the back of the PTFE gasket attached to tape.



Step 5. *Figure 5*

Install the valve ball, valve seat and o-ring.



Step 6. *Figure 6*

Center the gasket so that it evenly covers the o-ring and seat areas.



Step 7. *Figure 7*

Gently apply pressure to gasket to ensure the adhesive maintains a positive seal to stay in place during pump assembly.

EXPLODED VIEW & PARTS LISTING

P1 PLASTIC

Rubber-Fitted

EXPLODED VIEW

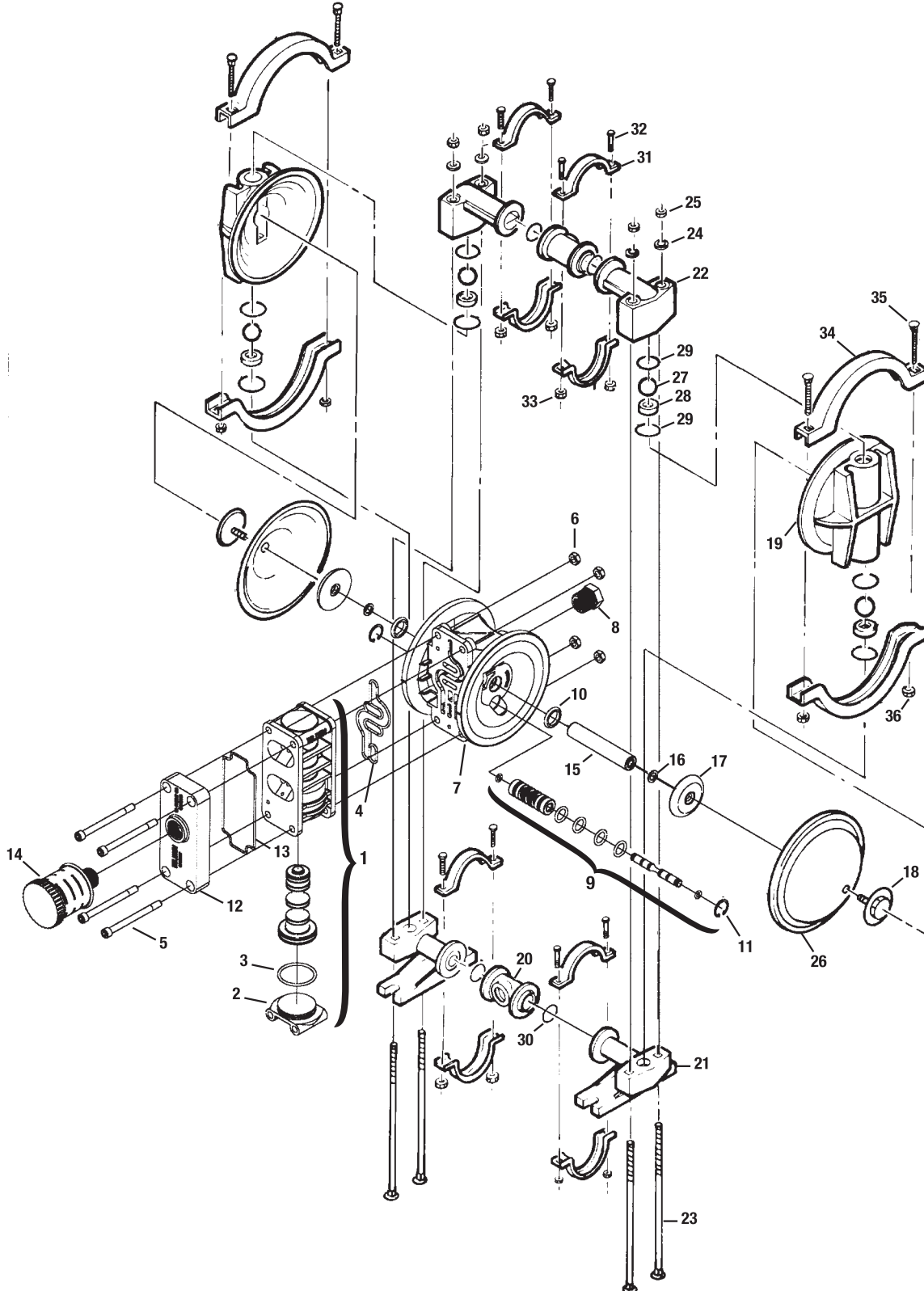

EXPLODED VIEW & PARTS LISTING

P1 PLASTIC

Rubber-Fitted

PARTS LISTING

Item	Part Description	Qty. Per Pump	P1/ PPPPP P/N	P1/ KPPPP P/N
1	Pro-Flo® Air Valve Assembly¹	1	01-2010-20	01-2010-20
2	End Cap	1	01-2332-20	01-2332-20
3	O-Ring, End Cap	1	01-2395-52	01-2395-52
4	Gasket, Air Valve	1	01-2615-52	01-2615-52
5	Screw, HSHC, Air Valve 1/4"-20	4	01-6001-03	01-6001-03
6	Nut, Hex, 1/2"-20	4	04-6400-03	04-6400-03
7	Center Section Assembly	1	01-3140-20	01-3140-20
8	Bushing, Reducer	1	01-6950-20	01-6950-20
9	Removable Pilot Sleeve Assembly	1	01-3880-99	01-3880-99
10	Glyd™ Ring II	2	01-3220-55	01-3220-55
11	Retaining Ring	2	00-2650-03	00-2650-03
12	Muffler Plate	1	01-3181-20	01-3181-20
13	Gasket, Muffler Plate	1	01-3505-52	01-3505-52
14	Muffler	1	02-3510-99	02-3510-99
15	Shaft, Pro-Flo®	1	01-3810-03	01-3810-03
16	Disc Spring	2	01-6802-08	01-6802-08
17	Inner Piston	2	01-3711-08	01-3711-08
18	Outer Piston	2	01-4570-20-500	01-4570-20-500
19	Liquid Chamber	2	01-5000-20	01-5000-21
20	Manifold Tee Section	2	01-5160-20	01-5160-21
21	Inlet Manifold Elbow	2	01-5220-20	01-5220-21
22	Discharge Manifold Elbow	2	01-5230-20	01-5230-21
23	Screw, SHCS (Chamber Bolt)	4	01-6080-03	01-6080-03
24	Vertical Bolt Washer	4	01-6730-03	01-6730-03
25	Vertical Bolt Nut	4	04-6400-03	04-6400-03
26	Diaphragm	2	*	*
27	Valve Ball	4	*	*
28	Valve Seat	4	01-1120-21-500	01-1120-21-500
29	Valve Seat O-Ring	8	*	*
30	Manifold O-Ring	4	*	*
31	Small Clamp Band	8	01-7100-03S	01-7100-03S
32	Small Clamp Band Bolt	8	01-6101-03	01-6101-03
33	Small Clamp Band Nut	8	01-6400-03	01-6400-03
34	Large Clamp Band	4	01-7300-03S	01-7300-03S
35	Large Clamp Band Bolt	4	01-6070-03	01-6070-03
36	Large Clamp Band Nut	4	04-6400-03	04-6400-03
37	Gasket Tape & Donuts		N/A	N/A

¹Air Valve Assembly includes items 2 and 3.

*Refer to corresponding elastomer chart in Section 10.

All boldface items are primary wear parts.

EXPLODED VIEW & PARTS LISTING

P1 PLASTIC

PTFE-Fitted

EXPLODED VIEW

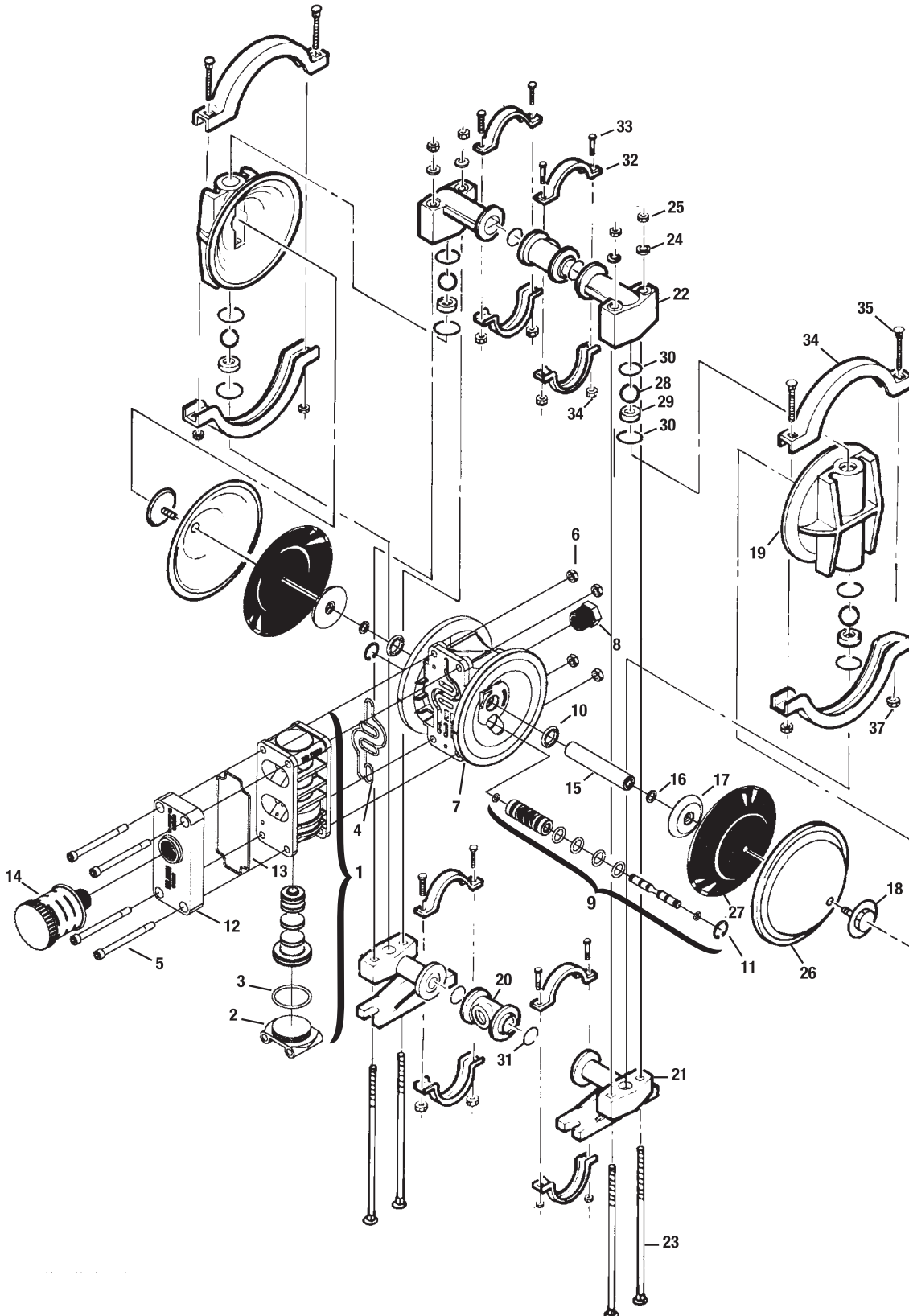

EXPLODED VIEW & PARTS LISTING

P1 PLASTIC

PTFE-Fitted

PARTS LISTING

Item	Part Description	Qty. Per Pump	P1/ P/PPPP P/N	P1/ P/PPPP/0502 P/N	P1/ K/PPPP P/N	P1/ K/PPPP/0502 P/N	P1/ T/PPPP/0502 P/N
1	Pro-Flo® Air Valve Assembly¹	1	01-2010-20	01-2010-20	01-2010-20	01-2010-20	01-2010-20
2	End Cap	1	01-2332-20	01-2332-20	01-2332-20	01-2332-20	01-2332-20
3	O-Ring, End Cap	1	01-2395-52	01-2395-52	01-2395-52	01-2395-52	01-2395-52
4	Gasket, Air Valve	1	01-2615-52	01-2615-52	01-2615-52	01-2615-52	01-2615-52
5	Screw, HSHC, Air Valve 1/4"-20	4	01-6001-03	01-6001-05	01-6001-03	01-6001-05	01-6001-05
6	Nut, Hex, 1/4"-20	4	04-6400-03	04-6400-05	04-6400-03	04-6400-05	04-6400-05
7	Center Section Assembly	1	01-3140-20	01-3140-20	01-3140-20	01-3140-20	01-3140-20
8	Bushing, Reducer	1	01-6950-20	01-6950-20	01-6950-20	01-6950-20	01-6950-20
9	Removable Pilot Sleeve Assembly	1	01-3880-99	01-3880-99	01-3880-99	01-3880-99	01-3880-99
10	Glyd™ Ring II	2	01-3220-55	01-3220-55	01-3220-55	01-3220-55	01-3220-55
11	Retaining Ring	2	00-2650-03	00-2650-03	00-2650-03	00-2650-03	00-2650-03
12	Muffler Plate	1	01-3181-20	01-3181-20	01-3181-20	01-3181-20	01-3181-20
13	Gasket, Muffler Plate	1	01-3505-52	01-3505-52	01-3505-52	01-3505-52	01-3505-52
14	Muffler	1	02-3510-99	02-3510-99	02-3510-99	02-3510-99	02-3510-99
15	Shaft, Pro-Flo®	1	01-3810-03	01-3810-03	01-3810-03	01-3810-03	01-3810-03
16	Disc Spring (Belleville Washer)	2	01-6802-08	01-6802-08	01-6802-08	01-6802-08	01-6802-08
17	Inner Piston	2	01-3711-08	01-3711-08	01-3711-08	01-3711-08	01-3711-08
18	Outer Piston	2	01-4570-20-500	01-4570-20-500	01-4570-21-500	01-4570-21-500	01-4570-22-500
19	Liquid Chamber	2	01-5000-20	01-5000-20	01-5000-21	01-5000-21	01-5000-22
20	Manifold Tee Section	2	01-5160-20	01-5160-20	01-5160-21	01-5160-21	01-5160-22
21	Inlet Manifold Elbow	2	01-5220-20	01-5220-20	01-5220-21	01-5220-21	01-5220-22
22	Discharge Manifold Elbow	2	01-5230-20	01-5230-20	01-5230-21	01-5230-21	01-5230-22
23	Screw, SHCS (Chamber Bolt)	4	01-6080-03	01-6080-05	01-6080-03	01-6080-05	01-6080-05
24	Vertical Bolt Washer	4	01-6730-03	01-6730-05	01-6730-03	01-6730-05	01-6730-05
25	Vertical Bolt Nut	4	04-6400-03	04-6400-05	04-6400-03	04-6400-05	04-6400-05
26	PTFE Primary Diaphragm	2	01-1010-55	01-1010-55	01-1010-55	01-1010-55	01-1010-55
27	Neoprene Backup Diaphragm	2	01-1060-51	01-1060-51	01-1060-51	01-1060-51	01-1060-51
28	Valve Ball	4	01-1080-55	01-1080-55	01-1080-55	01-1080-55	01-1080-55
29	Valve Seat	4	01-1120-21-500	01-1120-21-500	01-1120-21-500	01-1120-21-500	01-1120-22-500
30	Valve Seat O-Ring	8	00-1260-60	00-1260-60	00-1260-60	00-1260-60	00-1260-60
31	Manifold O-Ring	4	01-1300-60-500	01-1300-60-500	01-1300-60-500	01-1300-60-500	01-1300-60-500
32	Small Clamp Band	8	01-7100-03S	01-7100-05S	01-7100-03S	01-7100-05S	01-7100-05S
33	Small Clamp Band Bolt	8	01-6101-03	01-6101-05	01-6101-03	01-6101-05	01-6101-05
34	Small Clamp Band Nut	8	01-6400-03	01-6400-05	01-6400-03	01-6400-05	01-6400-05
35	Large Clamp Band	4	01-7300-03S	01-7300-05S	01-7300-03S	01-7300-05S	01-7300-05S
36	Large Clamp Band Bolt	4	01-6070-03	01-6070-05	01-6070-03	01-6070-05	01-6070-05
37	Large Clamp Band Nut	4	04-6400-03	04-6400-05	04-6400-03	04-6400-05	04-6400-05
38	Gasket Tape & Donuts	1	01-9500-99	01-9500-99	01-9501-99	01-9501-99	01-9501-99

¹Air Valve Assembly includes items 2 and 3.

*Refer to corresponding elastomer chart in Section 10.

0502 Specialty Code = PFA-Coated Hardware

All boldface items are primary wear parts.

ELASTOMER OPTIONS

ELASTOMER OPTIONS FOR MODEL P1 PLASTIC PUMPS

Material	Diaphragm P/N	Valve Ball P/N	Valve Seat* P/N	Valve Seat O-Ring P/N	Manifold O-Ring P/N
Polyurethane	01-1010-50	01-1080-50	N/A	01-1200-50	01-1300-50
Buna-N	01-1010-52	01-1080-52	N/A	01-1200-52	01-1300-52
Viton®	01-1010-53	01-1080-53	01-1120-531	N/A	N/A
Wil-Flex™	01-1010-582	01-1080-58	N/A	01-1200-58	01-1300-58
Saniflex™	01-1010-56	01-1080-56	N/A	01-1200-56	01-1300-56
PTFE ³	01-1010-55	01-1080-55	01-1120-22-500	N/A	N/A
PTFE with integral piston	01-1030-55	N/A	N/A	N/A	N/A
PVDF	N/A	N/A	01-1120-21-500	N/A	N/A
PTFE Encapsulated/ Viton®	N/A	N/A	N/A	00-1260-60	01-1300-60-500

³Must be used with part number 01-5010-21-500.

PTFE diaphragms require Neoprene back-up diaphragms (P/N 01-1060-51). P1 Ultrapure pump series require high-temp Buna-N back-up diaphragms (P/N 01-1060-61).

*Rubber valve seats do not require o-rings.

WARRANTY

Each and every product manufactured by Wilden Pump and Engineering, LLC is built to meet the highest standards of quality. Every pump is functionally tested to insure integrity of operation.

Wilden Pump and Engineering, LLC warrants that pumps, accessories and parts manufactured or supplied by it to be free from defects in material and workmanship for a period of five (5) years from date of installation or six (6) years from date of manufacture, whichever comes first. Failure due to normal wear, misapplication, or abuse is, of course, excluded from this warranty.

Since the use of Wilden pumps and parts is beyond our control, we cannot guarantee the suitability of any pump or part for a particular application and Wilden Pump and Engineering, LLC shall not be liable for any consequential damage or expense arising from the use or misuse of its products on any application. Responsibility is limited solely to replacement or repair of defective Wilden pumps and parts.

All decisions as to the cause of failure are the sole determination of Wilden Pump and Engineering, LLC.

Prior approval must be obtained from Wilden for return of any items for warranty consideration and must be accompanied by the appropriate MSDS for the product(s) involved. A Return Goods Tag, obtained from an authorized Wilden distributor, must be included with the items which must be shipped freight prepaid.

The foregoing warranty is exclusive and in lieu of all other warranties expressed or implied (whether written or oral) including all implied warranties of merchantability and fitness for any particular purpose. No distributor or other person is authorized to assume any liability or obligation for Wilden Pump and Engineering, LLC other than expressly provided herein.

PLEASE PRINT OR TYPE AND FAX TO WILDEN

PUMP INFORMATION			
Item # _____		Serial # _____	
Company Where Purchased _____			
YOUR INFORMATION			
Company Name _____			
Industry _____			
Name _____		Title _____	
Street Address _____			
City _____	State _____	Postal Code _____	Country _____
Telephone _____	Fax _____	E-mail _____	Web Address _____
Number of pumps in facility? _____		Number of Wilden pumps? _____	
Types of pumps in facility (check all that apply): <input type="checkbox"/> Diaphragm <input type="checkbox"/> Centrifugal <input type="checkbox"/> Gear <input type="checkbox"/> Submersible <input type="checkbox"/> Lobe			
<input type="checkbox"/> Other _____			
Media being pumped? _____			
How did you hear of Wilden Pump? <input type="checkbox"/> Trade Journal <input type="checkbox"/> Trade Show <input type="checkbox"/> Internet/E-mail <input type="checkbox"/> Distributor			
<input type="checkbox"/> Other _____			

ONCE COMPLETE, FAX TO (909) 783-3440

NOTE: WARRANTY VOID IF PAGE IS NOT FAXED TO WILDEN

WILDEN PUMP & ENGINEERING, LLC