

A.025

Original™ Series **PLASTIC** Pumps

EOM

Engineering
Operation &
Maintenance



Simplify your process

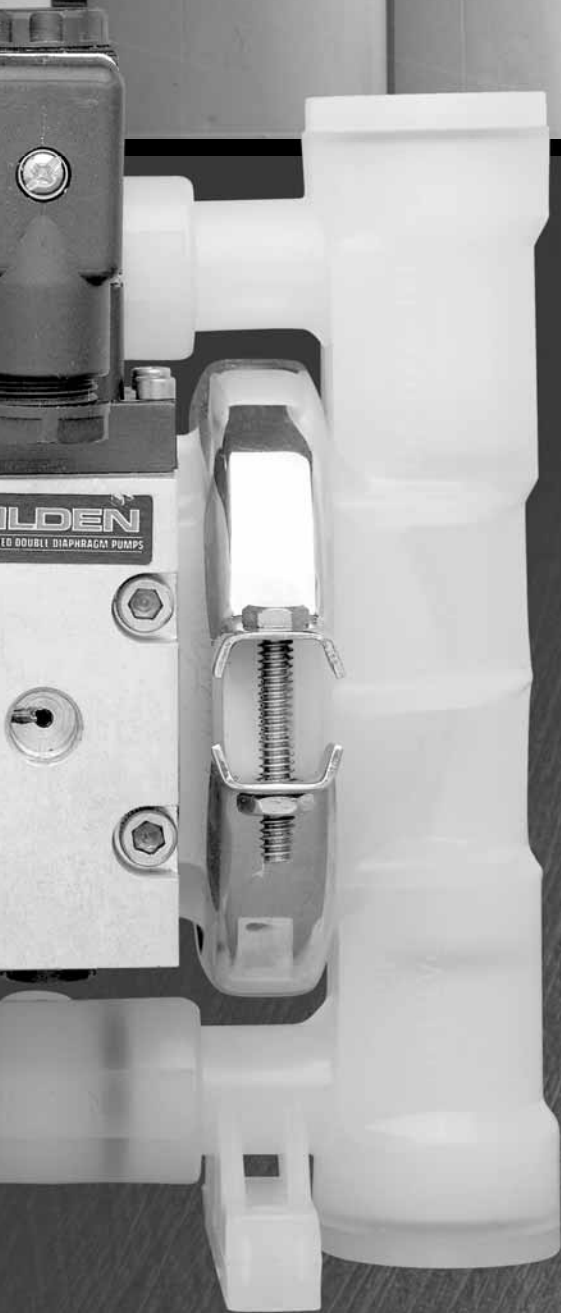

ACCUFLO™
SOLENOID PUMP TECHNOLOGY

WILDEN®
A **DOVER** COMPANY



WIL-10020-E-04
REPLACES WIL-10020-E-03

TABLE OF CONTENTS

	PAGE #
SECTION 1 – CAUTIONS – READ FIRST!	1
SECTION 2 – PUMP DESIGNATION SYSTEM	2
SECTION 3 – HOW IT WORKS (PUMP & AIR SYSTEMS)	3
SECTION 4 – DIMENSIONAL DRAWINGS	
A. A.025T PLASTIC (T-series Center Section)	4
B. A.025B PLASTIC (Adapter Block with T-series Center Section).....	4
C. A.025P PLASTIC (P-series Center Section).....	5
D. A.025B PLASTIC (Adapter Block with P-series Center Section).....	5
SECTION 5 – PERFORMANCE CURVES	
A. A.025T PLASTIC Rubber Fitted (T-series Center Section).....	6
B. A.025T PLASTIC PTFE Fitted (T-series Center Section).....	6
C. A.025P PLASTIC Rubber Fitted (P-series Center Section)	7
D. A.025P PLASTIC PTFE Fitted (P-series Center Section).....	7
SECTION 6 – 70/30 OPERATING CONDITION	
A. A.025T PLASTIC Rubber Fitted (T-series Center Section).....	8
A. A.025T PLASTIC PTFE Fitted (T-series Center Section).....	8
B. A.025P PLASTIC Rubber Fitted (P-series Center Section)	8
B. A.025P PLASTIC PTFE Fitted (P-series Center Section).....	8
SECTION 7 – INSTALLATION & OPERATION	
A. Installation.....	9
B. Operating Principles.....	10
C. Operation and Maintenance	10
D. Troubleshooting	11
SECTION 8 – DIRECTIONS FOR DISASSEMBLY/REASSEMBLY	
A. A.025T, A.025P and A.025B Wetted Path.....	12
B. Reassembly Hints & Tips.....	15
SECTION 9 – EXPLODED VIEW/PARTS LISTING	
A. A.025T PLASTIC (T-series Center Section)	16
B. A.025P PLASTIC (P-series Center Section).....	18
SECTION 10 – ELASTOMER OPTIONS/ELECTRICAL INFORMATION	
A. Elastomer Options	20
B. Electrical Information	20

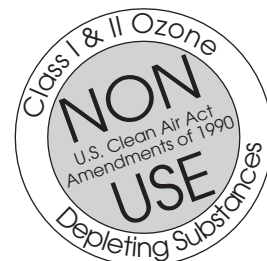

SECTION 1

A.025 PLASTIC CAUTIONS – READ FIRST!



TEMPERATURE LIMITS:

Polypropylene 0°C to 79°C 32°F to 175°F

PVDF -12°C to 107°C 10°F to 225°F

Buna-N -12.2°C to 82.2°C 10°F to 180°F

Viton® -40°C to 176.7°C -40°F to 350°F

Wil-Flex™ -40°C to 107.2°C -40°F to 225°F

PTFE 4.4°C to 104.4°C 40°F to 220°F



CAUTION: When choosing pump materials, be sure to check the temperature limits for all wetted components. Example: Viton® has a maximum limit of 176.7°C (350°F) but polypropylene has a maximum limit of only 79°C (175°F).



CAUTION: Maximum temperature limits are based upon mechanical stress only. Certain chemicals will significantly reduce maximum safe operating temperatures. Consult engineering guide for chemical compatibility and temperature limits.



CAUTION: Always wear safety glasses when operating pump. If diaphragm rupture occurs, material being pumped may be forced out air exhaust.



WARNING: Prevention of static sparking — If static sparking occurs, fire or explosion could result. Pump, valves, and containers must be properly grounded when handling flammable fluids and whenever discharge of static electricity is a hazard.



CAUTION: Do not exceed 8.6 bar (125 psig) air supply pressure.



CAUTION: Before any maintenance or repair is attempted, the compressed air line to the pump should be disconnected and all air pressure allowed to bleed from pump. Disconnect all intake, discharge and air lines. Drain the pump by turning it upside down and allowing any fluid to flow into a suitable container.



CAUTION: Blow out air line for 10 to 20 seconds before attaching to pump to make sure all pipe line debris is clear. Use an in-line air filter. A 5µ (micron) air filter is recommended.



NOTE: Tighten clamp bands and retainers prior to installation. Fittings may loosen during transportation.



NOTE: Before starting disassembly, mark a line from each liquid chamber to its corresponding air chamber. This line will assist in proper alignment during reassembly.



CAUTION: Verify the chemical compatibility of the process and cleaning fluid to the pump's component materials in the Chemical Resistance Guide (see E4).



NOTE: Plastic series pumps are made of virgin plastic and are not UV stabilized. Direct sunlight for prolonged periods can cause deterioration of plastics.



CAUTION: The A.025 Pump is not submersible

SECTION 2

WILDEN PUMP DESIGNATION SYSTEM

A.025 ORIGINAL™ PLASTIC

6 mm (1/4") Pump
Maximum Flow Rate:
10.6 LPM (2.8 GPM)

LEGEND

A.025 X / XXXXX / XXX / XX / XXX / XXXX

MODEL

AIR SYSTEM BASE TYPE

WETTED PARTS & OUTER PISTON

CENTER SECTION

AIR VALVE

DIAPHRAGMS

VALVE BALLS

O-RINGS

VALVE SEAT

SPECIALTY CODE

(if applicable)

MATERIAL CODES

AIR SYSTEM BASE TYPE

B = ADAPTER BLOCK
P = PRO-FLO®
T = TURBO-FLO™

WETTED PARTS & OUTER PISTON

KK = PVDF / PVDF
KZ = PVDF / NO PISTON
PP = POLYPROPYLENE /
POLYPROPYLENE
PZ = POLYPROPYLENE /
NO PISTON

CENTER SECTION

PP = POLYPROPYLENE

AIR VALVE

A = ALUMINUM
P = POLYPROPYLENE
U = UHMW (Available for A.025B
only)

DIAPHRAGMS

BNS = BUNA-N (Red Dot)
TNL = PTFE W/ NEOPRENE
BACK-UP O-RING,
IPD (White)
WFS = WIL-FLEX™ [Santoprene®
(Orange Dot)]

VALVE SEAT

K = PVDF
P = POLYPROPYLENE

VALVE SEAT O-RING

BN = BUNA-N
TV = PTFE ENCAP. VITON®
WF = WIL-FLEX™ [Santoprene®]

SPECIALTY CODES

- | | |
|---|--|
| 0150 Accu-Flo™, 24V DC coil | 0170 Accu-Flo™, 110V AC x-proof coil,
PFA coated hardware |
| 0151 Accu-Flo™, 24V AC / 12V DC coil | 0180 Accu-Flo™, 24V AC / 12V DC coil,
PFA coated hardware |
| 0153 Accu-Flo™, 24V AC / 12V DC x-proof coil | 0181 Accu-Flo™, 24V AC / 12V DC x-proof coil,
PFA coated hardware |
| 0154 Accu-Flo™, 24V DC x-proof coil | 0184 Accu-Flo™, 24V DC coil, PFA coated hardware |
| 0155 Accu-Flo™, 110V coil | 0185 Accu-Flo™, 24V DC x-proof coil,
PFA coated hardware |
| 0156 Accu-Flo™, 110V AC x-proof coil | |
| 0157 Accu-Flo™, 24V DC x-proof coil, Intl.,
PTB approved | |
| 0169 Accu-Flo™, 110V AC coil,
PFA coated hardware | |

NOTE: MOST ELASTOMERIC MATERIALS USE COLORED DOTS FOR IDENTIFICATION.

THE THREE ACCU-FLO™ OPTIONS AVAILABLE:

1. AxT: This is the same Accu-Flo™ configuration that has been available from Wilden since March 1994. An aluminum solenoid valve is attached directly to a T-series center section and the shaft/inner piston configuration is altered.
2. AxP: This option uses a plastic (polypropylene or acetal) spacer that is assembled between the Pro-Flo® air valve and the Pro-Flo® center section. The same solenoid operator – coil assembly that is found on AxT pumps is assembled on the plastic spacer discussed above for electronic interface. This spacer combined with the Pro-Flo® air valve replaces the aluminum air valve used in the AxT with a more chemically resistant option. Spacers will be available

in the 1/4-in, 1/2-in, and 1-in sizes. The use of the Pro-Flo® ADS provides additional flow in most applications (refer to EOM for details). The AxP provides the Pro-Flo® benefits of lower start-up pressure, reduced blow-by, and increased life.

3. AxB: This option uses an Adapter Block in place of an air valve. A user supplied, 4-way pneumatic valve must be used in conjunction with this technology. This configuration enables the solenoid valve to be remotely installed, preventing chemical attack in very aggressive environments. Adapter Blocks are available for both the T and P-series center sections in all pump sizes. (See EOM AxB for details.) Note: The "x" in the above Accu-Flo™ descriptions are used in place of a pump model size. See Pump Designation System chart above.

Viton is a registered trademark of DuPont Dow Elastomers.

SECTION 3

THE WILDEN PUMP — HOW IT WORKS

The Wilden diaphragm pump is an air-operated, positive displacement, self-priming pump. These drawings show the flow pattern through the pump upon its initial stroke. It is assumed the pump has no fluid in it prior to its initial stroke.

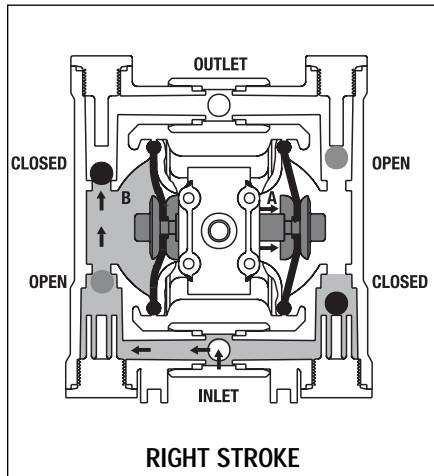

FIGURE 1 When the solenoid is energized, the air valve directs pressure to the back side of diaphragm A. The compressed air is applied directly to the liquid column separated by elastomeric diaphragms. The diaphragm acts as a membrane between the compressed air and the liquid, balancing the load and removing mechanical stress from the diaphragm. The compressed air moves the diaphragm away from the center section of the pump. The opposite diaphragm is pulled in by the shaft connected to the pressurized diaphragm. Diaphragm B is on its suction stroke; air behind the diaphragm has been forced out to the atmosphere through the exhaust port. The movement of diaphragm B toward the center section of the pump creates a vacuum within chamber B. Atmospheric pressure forces fluid into the inlet manifold of the pump. The inlet valve ball is forced off of its seat allowing the fluid being pumped to fill the liquid chamber (see shaded area).

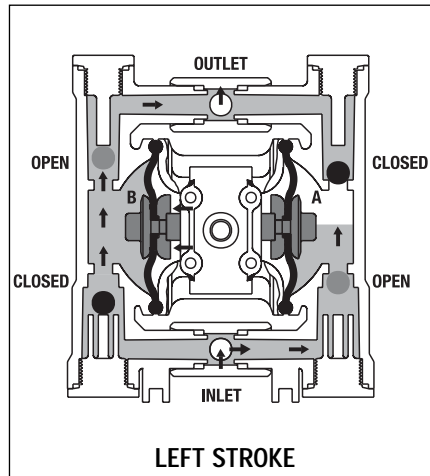

FIGURE 2 When the solenoid valve is deenergized, the air valve redirects pressurized air to the back side of diaphragm B. The pressurized air forces diaphragm B away from the center section while pulling diaphragm A to the center section. Diaphragm B is now on its discharge stroke. Diaphragm B forces the inlet valve ball onto its seat due to the hydraulic forces developed in the liquid chamber and manifold of the pump. These same hydraulic forces lift the discharge valve ball off of its seat, while the opposite discharge valve ball is forced onto its seat, forcing fluid to flow through the pump discharge. The movement of diaphragm A toward the center section of the pump creates a vacuum within liquid chamber A. Atmospheric pressure forces fluid into the inlet manifold of the pump. The inlet valve ball is forced off of its seat allowing the fluid being pumped to fill the liquid chamber.

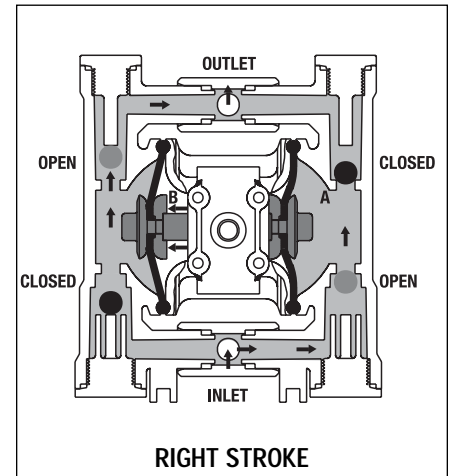
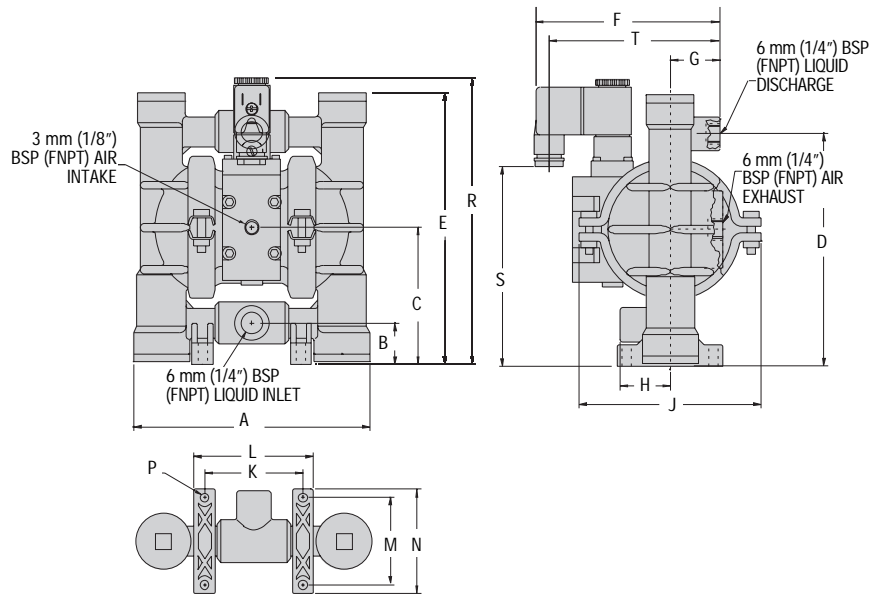

FIGURE 3 Once the solenoid valve is reenergized, the air is directed to the back side of diaphragm A, which starts diaphragm B on its exhaust stroke. As the pump reaches its original starting point, each diaphragm has gone through one intake and one discharge stroke. This constitutes one complete pumping cycle. The pump may take several cycles to completely prime depending on the conditions of the application.

SECTION 4A

DIMENSIONAL DRAWING A.025T PLASTIC ACCU-FLO™



DIMENSIONS

ITEM	METRIC (mm)	STANDARD (inch)
A	145	5.7
B	25	1.0
C	84	3.3
D	140	5.5
E	163	6.4
F	79	3.1
G	30	1.2
H	30	1.2
J	114	4.5
K	61	2.4
L	74	2.9
M	53	2.1
N	64	2.5
P	5	0.2
R	175	6.9
S	124	4.9
T	71	2.8

SECTION 4B

DIMENSIONAL DRAWING A.025B PLASTIC ACCU-FLO™ (T-SERIES CENTER SECTION)

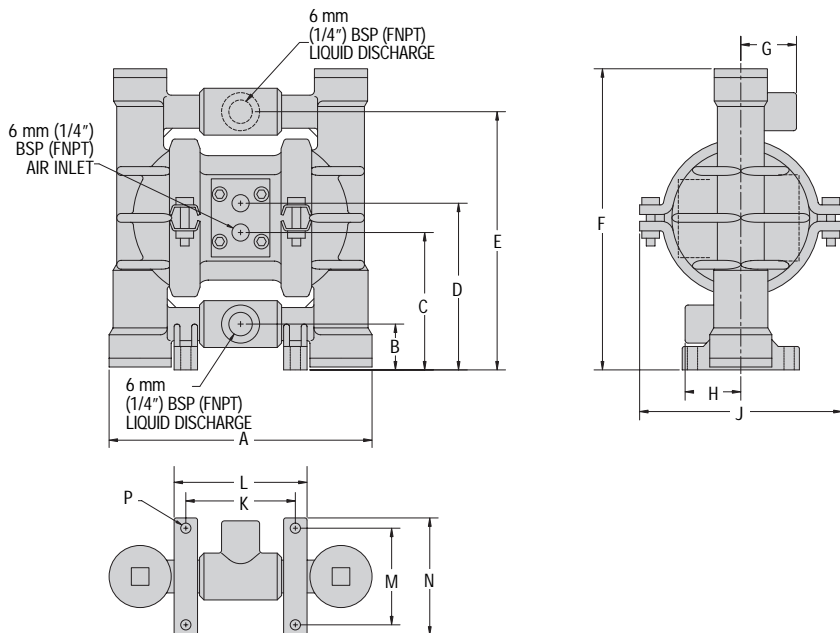

DIMENSIONS

ITEM	METRIC (mm)	STANDARD (inch)
A	145	5.7
B	25	1.0
C	74	2.9
D	94	3.7
E	140	5.5
F	163	6.4
G	30	1.2
H	30	1.2
J	114	4.5
K	61	2.4
L	74	2.9
M	53	2.1
N	64	2.5
P	5	0.2

SECTION 4C

DIMENSIONAL DRAWING A.025B PLASTIC ACCU-FLO™

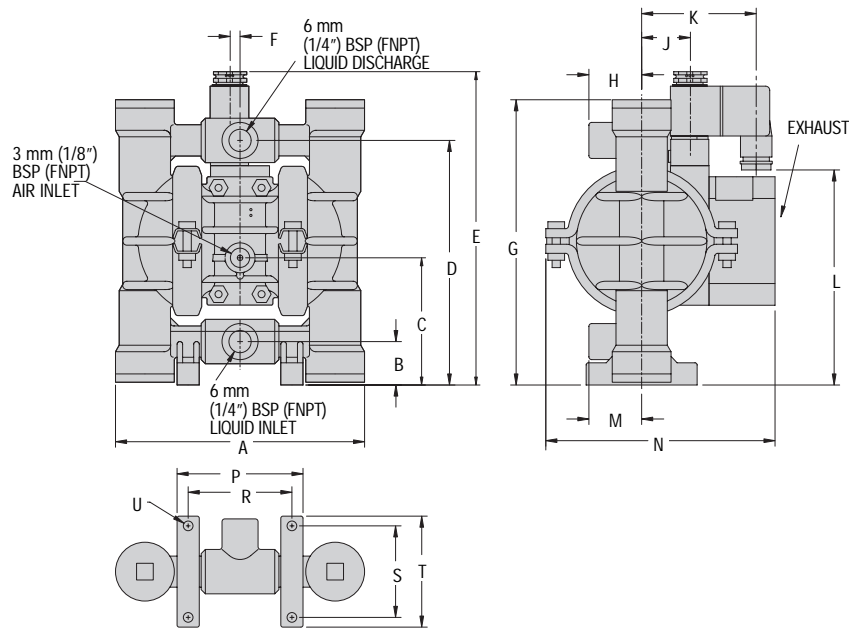

DIMENSIONS

ITEM	METRIC (mm)	STANDARD (inch)
A	145	5.7
B	25	1.0
C	74	2.9
D	140	5.5
E	180	7.1
F	8	0.3
G	163	6.4
H	30	1.2
J	28	1.1
K	66	2.6
L	122	4.8
M	30	1.2
N	132	5.2
P	74	2.9
R	61	2.4
S	53	2.1
T	64	2.5
U	5	0.2

SECTION 4D

DIMENSIONAL DRAWING A.025B PLASTIC ACCU-FLO™ (P-SERIES CENTER SECTION)

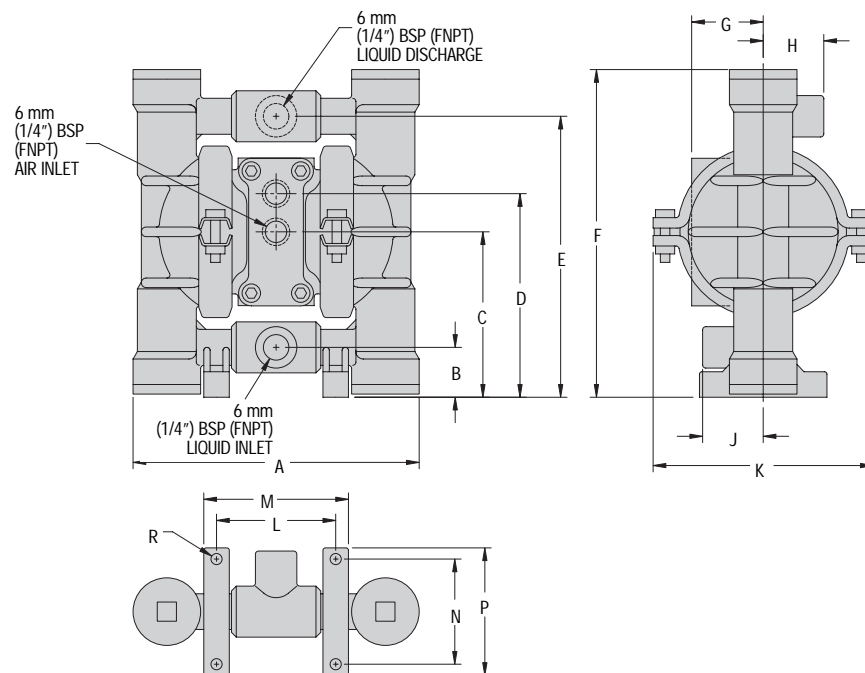

DIMENSIONS

ITEM	METRIC (mm)	STANDARD (inch)
A	145	5.7
B	25	1.0
C	79	3.1
D	84	3.3
E	140	5.5
F	163	6.4
G	30	1.2
H	30	1.2
J	30	1.2
K	132	5.2
L	61	2.4
M	74	2.9
N	53	2.1
P	64	2.5
R	5	1.2

SECTION 5A

PERFORMANCE

A.025T PLASTIC RUBBER-FITTED

Height..... 175 mm (6.9")
 Width..... 145 mm (5.7")
 Depth 107 mm (4.2")
 Est. Ship Weight ... Polypropylene 1kg (3 lbs)
 Air Inlet..... 3 mm (1/8")
 Inlet..... 6 mm (1/4")
 Outlet 6 mm (1/4")
 Suction Lift..... 2.94 m (9.6' Dry)
 9.32 m (30.6' Wet)

Displacement per
 Stroke 0.016 l (0.004 gal.)¹
 Max. Flow Rate..... 11.7 lpm (3.1 gpm)
 Max. Size Solids 0.4 mm (1/64")

¹Displacement per stroke was calculated at 4.8 bar (70 psig) air inlet pressure against a 2 bar (30 psig) head pressure.

Example: To pump 3.8 lpm (1 gpm) against a discharge pressure head of 3.2 bar (46 psig) requires 4.1 bar (60 psig) and 8.3 Nm³/h (2.9 scfm) air consumption.

Caution: Do not exceed 8.6 bar (125 psig) air supply pressure.

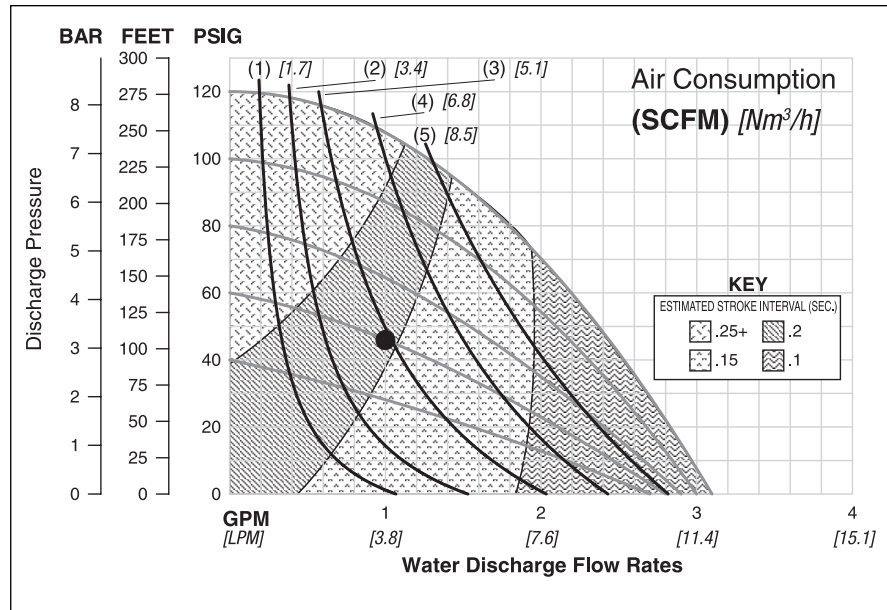

Flow rates indicated on chart were determined by pumping water.

For optimum life and performance, pumps should be specified so that daily operation parameters will fall in the center of the pump performance curve.

SECTION 5A

PERFORMANCE

A.025T PLASTIC PTFE-FITTED

Height..... 175 mm (6.9")
 Width..... 145 mm (5.7")
 Depth 107 mm (4.2")
 Est. Ship Weight ... Polypropylene 1kg (3 lbs)
 Air Inlet..... 3 mm (1/8")
 Inlet..... 6 mm (1/4")
 Outlet 6 mm (1/4")
 Suction Lift..... 4.32 m (14.2' Dry)
 9.32 m (30.6' Wet)

Displacement per
 Stroke 0.017 l (0.005 gal.)¹
 Max. Flow Rate..... 11.7 lpm (3.1 gpm)
 Max. Size Solids 0.4 mm (1/64")

¹Displacement per stroke was calculated at 4.8 bar (70 psig) air inlet pressure against a 2 bar (30 psig) head pressure.

Example: To pump 3.8 lpm (1 gpm) against a discharge pressure head of 3.4 bar (49 psig) requires 4.1 bar (60 psig) and 4.3 Nm³/h (2.5 scfm) air consumption.

Caution: Do not exceed 8.6 bar (125 psig) air supply pressure.

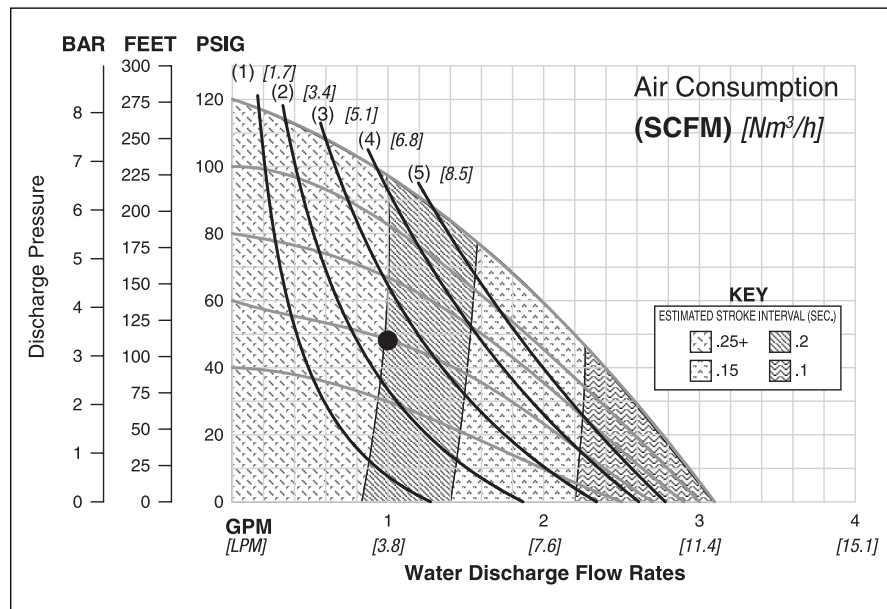

Flow rates indicated on chart were determined by pumping water.

For optimum life and performance, pumps should be specified so that daily operation parameters will fall in the center of the pump performance curve.

SECTION 5C

PERFORMANCE

A.025P PLASTIC RUBBER-FITTED

Height..... 180 mm (7.1")
 Width..... 145 mm (5.7")
 Depth 132 mm (5.2")
 Est. Ship Weight... Polypropylene 1kg (3 lbs)
 1 kg (PVDF 3 lbs)
 Air Inlet..... 3 mm (1/8")
 Inlet 6 mm (1/4")
 Outlet 6 mm (1/4")
 Suction Lift 4.14 m (13.6' Dry)
 9.32 m (30.6' Wet)

Displacement per
 Stroke 0.018 l (0.005 gal.)¹
 Max. Flow Rate..... 12.1 lpm (3.2 gpm)
 Max. Size Solids 0.4 mm (1/64")

¹Displacement per stroke was calculated at 4.8 bar (70 psig) air inlet pressure against a 2 bar (30 psig) head pressure.

Example: To pump 3.8 lpm (1 gpm) against a discharge pressure head of 2.8 bar (40 psig) requires 4.1 bar (60 psig) and 3.2 Nm³/h (1.9 scfm) air consumption.

Caution: Do not exceed 8.6 bar (125 psig) air supply pressure.

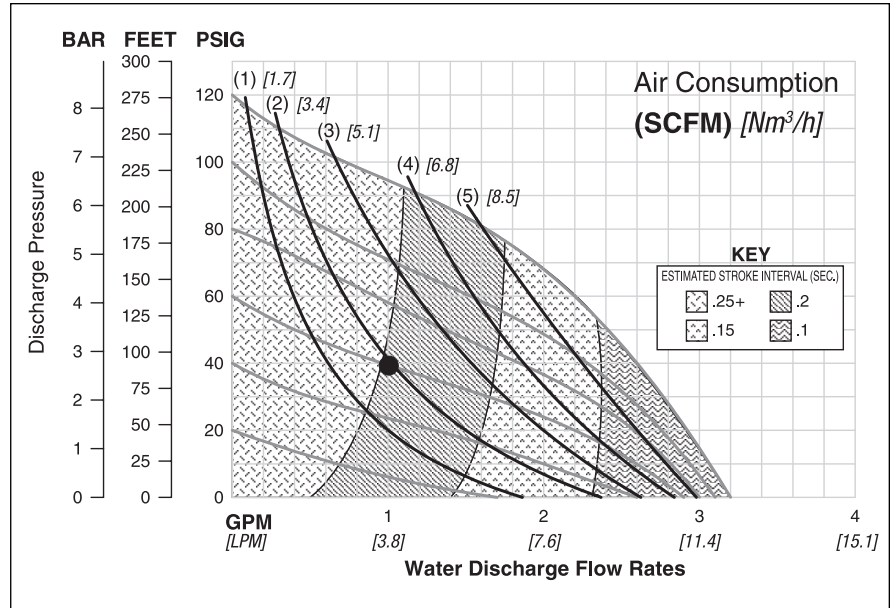

Flow rates indicated on chart were determined by pumping water.

For optimum life and performance, pumps should be specified so that daily operation parameters will fall in the center of the pump performance curve.

SECTION 5D

PERFORMANCE

A.025P PLASTIC PTFE-FITTED

Height..... 180 mm (7.1")
 Width..... 145 mm (5.7")
 Depth 132 mm (5.2")
 Est. Ship Weight... Polypropylene 1kg (3 lbs)
 1 kg (PVDF 3 lbs)
 Air Inlet..... 3 mm (1/8")
 Inlet 6 mm (1/4")
 Outlet 6 mm (1/4")
 Suction Lift 3.96 m (13.0' Dry)
 9.32 m (30.6' Wet)

Displacement per
 Stroke 0.017 l (0.005 gal.)¹
 Max. Flow Rate..... 11.7 lpm (3.1 gpm)
 Max. Size Solids 0.4 mm (1/64")

¹Displacement per stroke was calculated at 4.8 bar (70 psig) air inlet pressure against a 2 bar (30 psig) head pressure.

Example: To pump 3.8 lpm (1 gpm) against a discharge pressure head of 3.4 bar (49 psig) requires 4.1 bar (60 psig) and 4.3 Nm³/h (2.5 scfm) air consumption.

Caution: Do not exceed 8.6 bar (125 psig) air supply pressure.

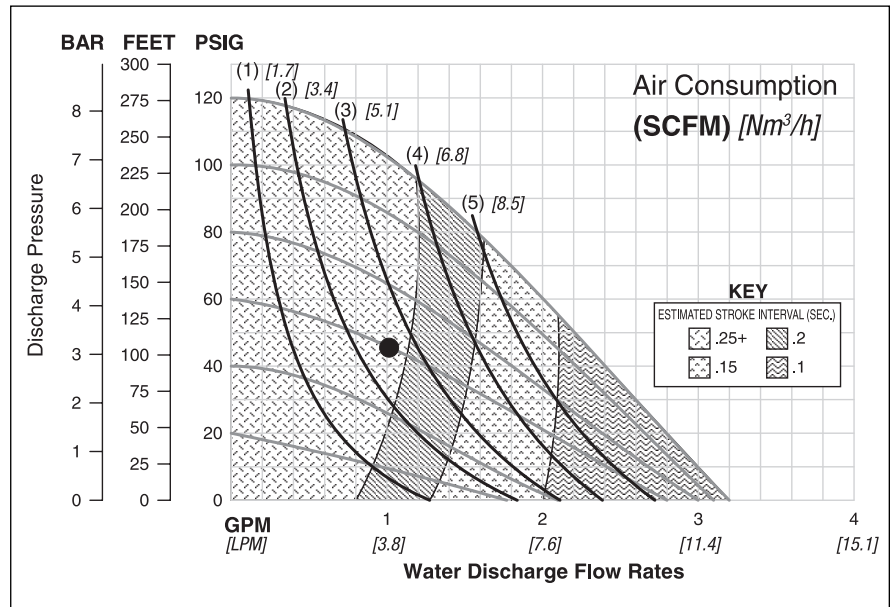

Flow rates indicated on chart were determined by pumping water.

For optimum life and performance, pumps should be specified so that daily operation parameters will fall in the center of the pump performance curve.

SECTION 6A

70/30 OPERATING CONDITION

A.025T PLASTIC ACCU-FLO™

These curves demonstrate the flow created when the stroke rate is modified under static air and fluid pressure condition. This curve can be applied to different pressure conditions to estimate the change in flow due to stroke rate.

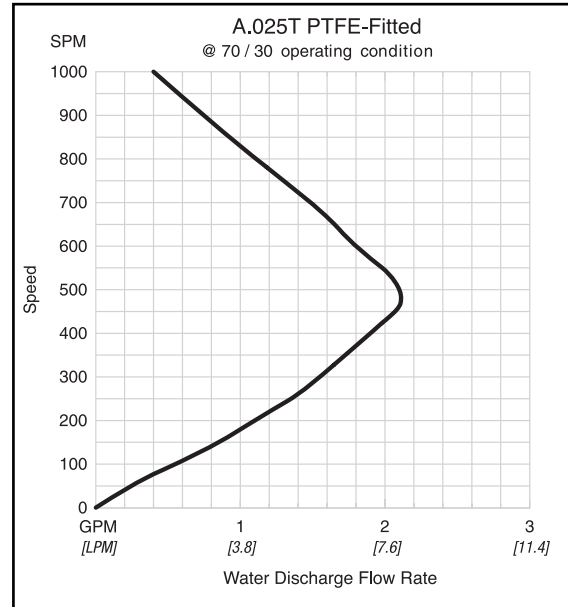
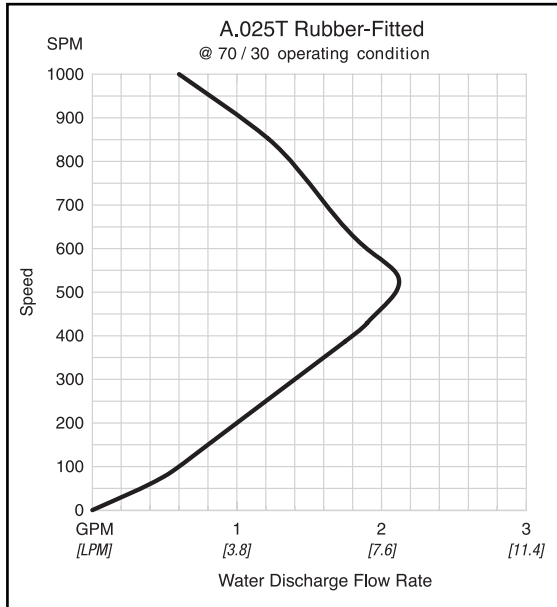

SECTION 6B

70/30 OPERATING CONDITION

A.025P PLASTIC ACCU-FLO™

These curves demonstrate the flow created when the stroke rate is modified under static air and fluid pressure condition. This curve can be applied to different pressure conditions to estimate the change in flow due to stroke rate.

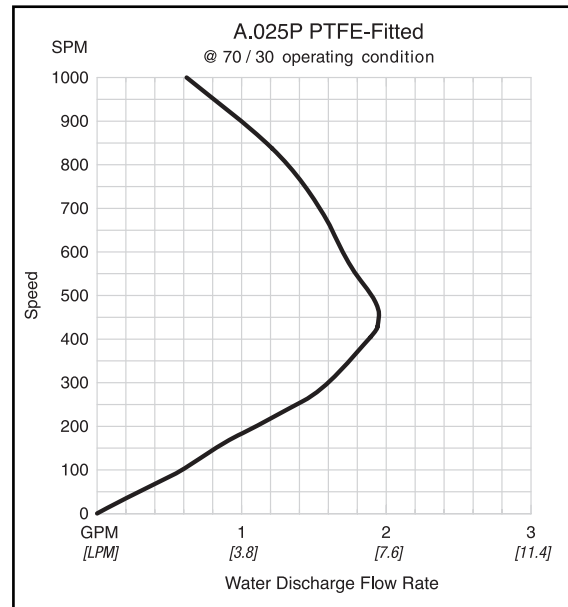
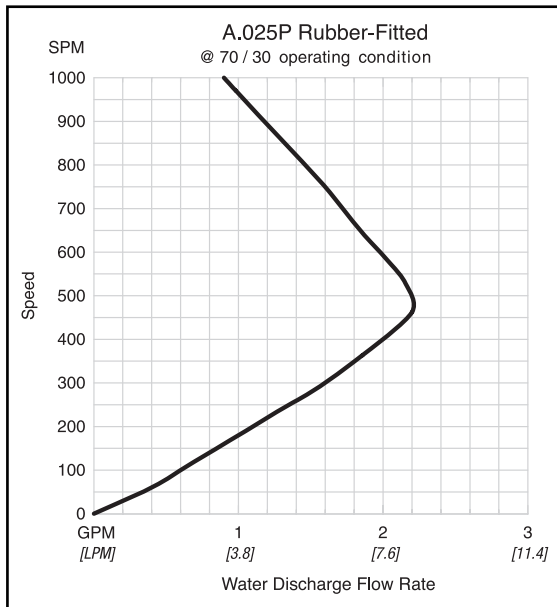

SECTION 7A

INSTALLATION

All Wilden pumps are manufactured with a variety of materials for the air distribution system, liquid path and elastomers. This variety is offered to satisfy the temperature, chemical compatibility, abrasion and flex life requirements for most applications. Consult manual for available materials and temperature limitations for this pump model.

For Accu-Flo™ models only, all wiring used to operate the pump should be placed and connected according to all applicable electrical codes. It is important that the wiring be of adequate gauge to carry the current required to operate the pump. In addition, it is necessary that the electrical power supply be large enough to supply the current required to operate the pump. Wiring should be above ground level if possible (in case of fluid spill or leakage), and all wiring and connections which could become wet or damp should be made watertight.

The suction pipe used for installation should be sized equal to, or greater than, the pump liquid inlet connection. This will minimize pump cavitation and potential blockages of the pump inlet. The discharge piping should also be sized equal to, or greater than, the pump liquid discharge connection. If the pump is to be used in a self-priming application, be sure that all connections are airtight and that the suction lift is within the pump's ability. (Consult manual for suction lift information.) Note: Materials of construction and elastomer materials have an effect on suction lift parameters.

INSTALLATION: Months of careful planning, study and selection efforts can result in unsatisfactory pump performance if installation details are left to chance.

Premature failure and long term dissatisfaction can be avoided if reasonable care is exercised throughout the installation process.

LOCATION: Noise, safety, and other logistical factors usually dictate that "utility" equipment be situated away from the production floor. Multiple installations with conflicting requirements can result in congested utility areas, leaving few choices for siting additional pumps.

Within the framework of these and other existing conditions, every pump should be located in such a way that four key factors are balanced against each other to maximum advantage.

1. **ACCESS:** First of all, the location should be accessible. If it is easy to reach the pump, maintenance personnel will have an easier time carrying out routine inspections and adjustments. Should major repairs become necessary, ease of access can play a key role in speeding the repair process and reducing total downtime.

2. **AIR SUPPLY:** Every pump location should have an air line large enough to supply the volume of air necessary to achieve the desired pumping rate. (Consult manual for performance information.) The use of an air filter before the

pump will ensure that the majority of pipeline contaminants will be eliminated. For best results, the pump should use an air filter, regulator system.

Sound levels are reduced below OSHA specifications using the standard Wilden muffler.

3. **ELEVATION:** Selecting a site that is well within the pump's dynamic lift capability will assure that a loss-of-prime condition will be avoided. In addition, pump efficiency can be adversely effected if proper attention is not given to site location.

4. **PIPING:** Final determination of the pump site should not be made until the piping problems of each possible location have been evaluated. The impact of current and future installations should be considered ahead of time to make sure that inadvertent restrictions are not created for any remaining sites.

The best choice possible will be a site involving the shortest and straightest hook-up of suction and discharge piping. Unnecessary elbows, bends, and fittings should be avoided. Pipe sizes should be selected so as to keep friction losses within practical limits. All piping should be supported independently of the pump to avoid damage. In addition, the piping should be aligned so as to avoid placing stress on the pump fittings.

Flexible hose can be installed to aid absorbing the forces created by the natural reciprocating action of the pump. If the pump is to be bolted down to a solid location, a mounting pad placed between the pump and the foundation will assist in minimizing pump vibration. Flexible connections between the pump and rigid piping will also assist in minimizing pump vibration. If quick-closing valves are installed at any point in the discharge system, or if pulsation within a system becomes a problem, a Wilden Equalizer surge dampener should be installed to protect the pump, piping and gauges from surges and water hammer. Installation of a tee at the discharge of the pump will allow the addition of an Equalizer to the system at a later date without requiring piping modifications. Installation of inlet and discharge isolation valves are also recommended to make service and repair easier.

Pumps in service with a positive suction head are most efficient when pressure is limited to 0.4-0.7 bar (7-10 psig). Premature diaphragm failure may occur if positive suction exceeds these recommended pressures.

A STRAINER SHOULD BE USED ON THE SUCTION LINE OF THE SYSTEM IF THERE IS A POSSIBILITY THAT SOLIDS ENTERING THE PUMP MAY EXCEED THE PUMP'S SOLIDS HANDLING CAPABILITIES.

PLEASE READ AND FOLLOW ALL CAUTIONS NOTED IN THIS MANUAL.

Pump should be thoroughly flushed before installing into process line.

Blow out air line for 10 to 20 seconds before attaching pump to clear all pipe line debris.

SECTION 7B

OPERATING PRINCIPLES BEHIND ACCU-FLO™ PUMPS

When the solenoid is unpowered, one air chamber is pressurized with air, while the opposite chamber is exhausted. When electric power is applied, the solenoid shifts, and the pressurized air chamber is exhausted while the opposite chamber is pressurized. By alternately applying and removing power, the solenoid-operated pump runs like a standard Wilden pump.

The speed of the pump is controlled electrically. Since each stroke is controlled by an electrical signal, the pump is ideal for batching and other electrically controlled dispensing applications.

Although the speed of the pump is controlled electrically, the air pressure is important. Air pressure displaces the fluid, and if the pressure is insufficient to complete the physical stroke before an electronic impulse signals the pump to shift, the stroke will not be completed, and the displacement per stroke will be reduced. This does not harm the unit in any way, but it may cause inaccuracy when attempting to batch specific quantities with high precision if this effect is not taken into account.

There are three coil voltage options available. One coil allows for 24V DC operation. The second coil option allows for operation with either 12V DC or 24V AC at 60 Hz and the third coil option allows for 110V AC operation.

ELECTRICAL CONNECTIONS

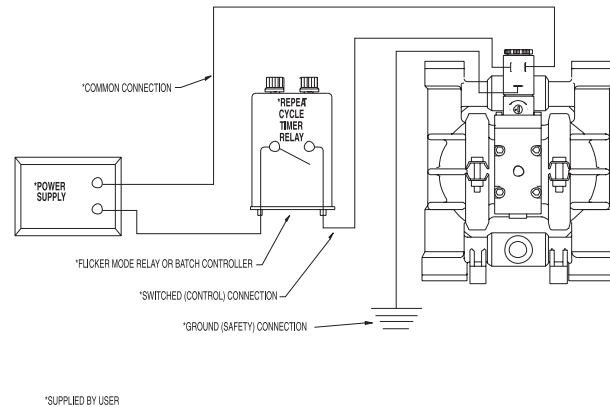

PLUMBING CONNECTIONS

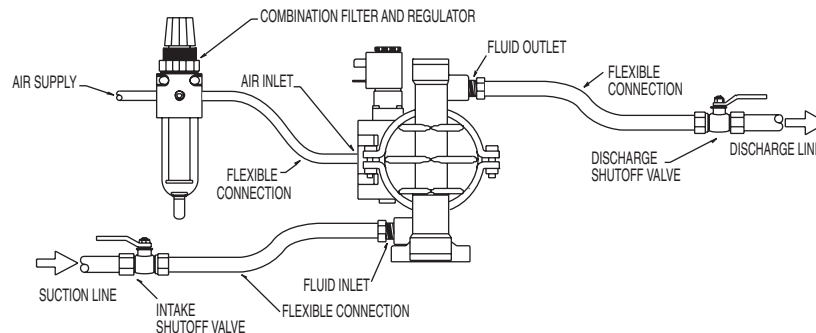

SECTION 7C - ACCU-FLO™

SUGGESTED OPERATION AND MAINTENANCE INSTRUCTIONS

For best results, the pumps should use an air filter and a regulator. The use of an air filter before the pump inlet will ensure that the majority of pipeline contaminants will be eliminated. The solenoid operated pump is permanently lubricated during assembly, and requires no additional lubrication under normal operation. If the unit runs under extreme conditions (continuous operation at high speeds), it may be necessary to relubricate the center block with a **Buna-N compatible NLGI Grade 2 grease** every 50 million cycles. Continuous lubrication with a compatible oil is not harmful, and will provide longer seal life, but it may flush all grease out of the unit.

Pump discharge rate is controlled electrically by varying the rate of alternation of the stroke signals. The pump will continue to shift if the liquid discharge line is closed, however no media will be pumped. This will not harm the pump in any way. The pump will not shift reliably unless the minimum supply pressure is provided. For the A.025T the minimum supply pressure for reliable operation is 2.7 bar (40 psig).

A muffler can be installed to reduce the amount of noise generated by the pump. Use of the specified Wilden muffler will reduce noise levels below OSHA specifications.

INSPECTIONS: Periodic inspections have been found to offer the best means for preventing unscheduled pump downtime.

Individuals responsible for checking and maintaining lubrication levels in the pumps should also check for any abnormal noise or leakage. Personnel familiar with the pumps' construction and service should be informed of any abnormalities that are detected.

RECORDS: When service is required, a record should be made of all necessary repairs and replacements. Over a period of time, such records can become a valuable tool for predicting and preventing future maintenance problems and unscheduled downtime. In addition, accurate records make it possible to identify pumps that are poorly suited to their applications.

TROUBLESHOOTING

Pump will not run.

1. Check for pressurized air at the inlet.
2. Check air inlet and filter for debris.
3. Connect a test lamp to the two wires which run to pump and ensure that the lamp cycles on and off.
4. Make sure that the air valve manual override (small red knob on front of valve) is switched to the "0" position.
5. Check pilot pressure vent at the top of the operator/coil assembly to ensure that it is not clogged.
6. Check for a worn out air valve. If air continually blows out the exhaust in very large quantities, the air valve seals may be worn beyond their ability to function. In this case, the valve must be replaced.

NOTE: Before the valve is scrapped, it is possible that it may be saved by completely disassembling the valve, cleaning all components and relubricating the valve.

Pump runs but little or no fluid comes out.

1. Check that the discharge isolation valve is not closed.
2. Check that the electronic signal is slow enough that the pump is able to complete each physical stroke before it is signaled to change direction. The time required to complete the stroke is determined by a variety of factors which include fluid viscosity and head pressure.
3. Check for pump cavitation; slow pump speed down to match the thickness of the material being pumped.

4. Check for sticking ball check valves. If the material being pumped is not compatible with the pump elastomers, swelling may occur. Replace ball check valves and o-ring with the proper elastomers.
5. Check to make sure that all suction connections are air tight, and that the clamp bands are properly tightened.

Pump rattles.

1. See E9 Troubleshooting Guide.
2. Create false discharge head or suction lift.

Pump air passages blocked with ice.

Check for excessive moisture in compressed air line. As the air expands out the exhaust during the operation of the pump, water vapor entrapped in the compressed air can freeze and block the air passageways in the pump. If this occurs, it may be necessary to install a coalescing filter, an air dryer, or a hot air generator for the compressed air.

Air bubbles in pump discharge.

1. Check for ruptured diaphragm.
2. Check tightness of clamp bands, and the integrity of the o-rings, especially at intake manifold.

Product comes out of the air exhaust.

1. Check for diaphragm rupture.
2. Check tightness of piston plates to shaft.

SECTION 8A

MODEL A.025

DIRECTIONS FOR DISASSEMBLY/REASSEMBLY

CAUTION: Before any maintenance or repair is attempted, the compressed air line to the pump should be disconnected and all air pressure allowed to bleed from the pump. Disconnect all intake, discharge, and air lines. Drain the pump by turning it upside down and allowing any fluid to flow into a suitable container. Be aware of any hazardous effects of contact with your process fluid.

The Wilden model A.025 is an air-operated, double-diaphragm pump with all wetted parts of polypropylene or PVDF. The single-piece center section, consisting of center block and air chambers, is molded from polypropylene. All fasteners and hardware are stainless steel. All o-rings used in the pump are of special materials and should only be replaced with factory-supplied parts.

PLEASE read all directions before starting disassembly.

TOOLS REQUIRED:

1/4" Socket Drive
3/8" Box Wrench
7/16" Wrench
3/16" Rod
Adjustable Wrench
Vise equipped with soft jaws (such as plywood, plastic or other suitable material)

NOTE: The model used for these instructions incorporates PTFE diaphragms and balls. Models with rubber/TPE diaphragms are the same except where noted.

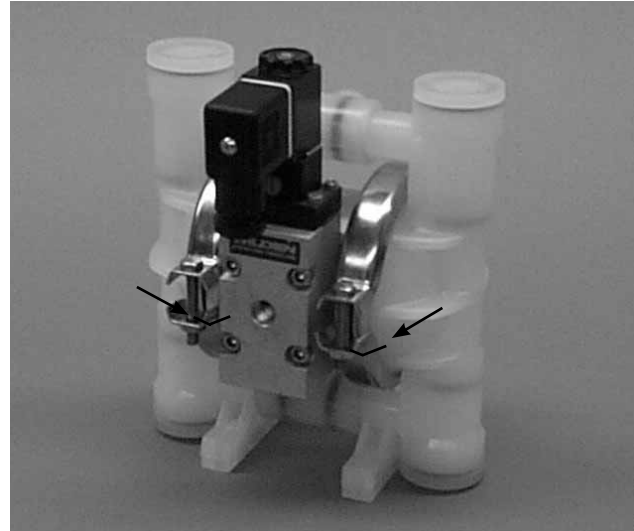

DISASSEMBLY:

Figure 1

Step 1.

Before actual disassembly is started, turn pump upside down and drain all liquid trapped in the pump into a suitable container. Be sure to use proper caution if liquid is corrosive or toxic. Mark each liquid chamber to its respective air chamber for easy alignment during reassembly.

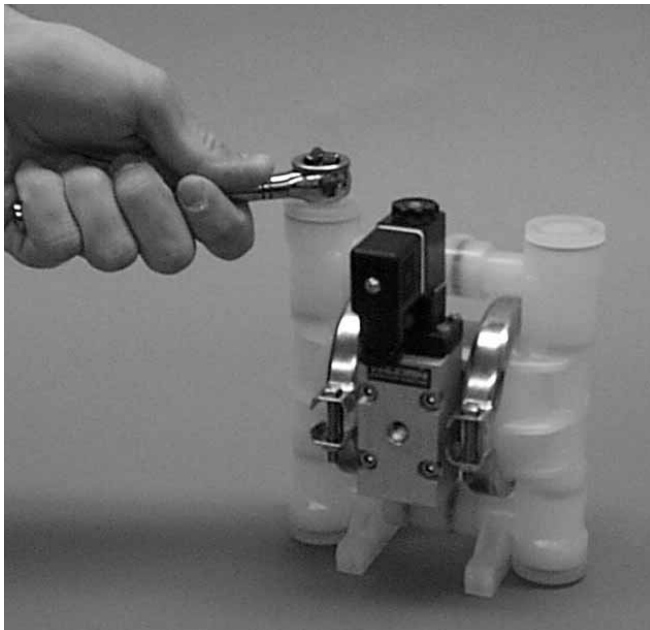

Step 2.

Figure 2

Using a 1/4" socket wrench, remove the top retainer.

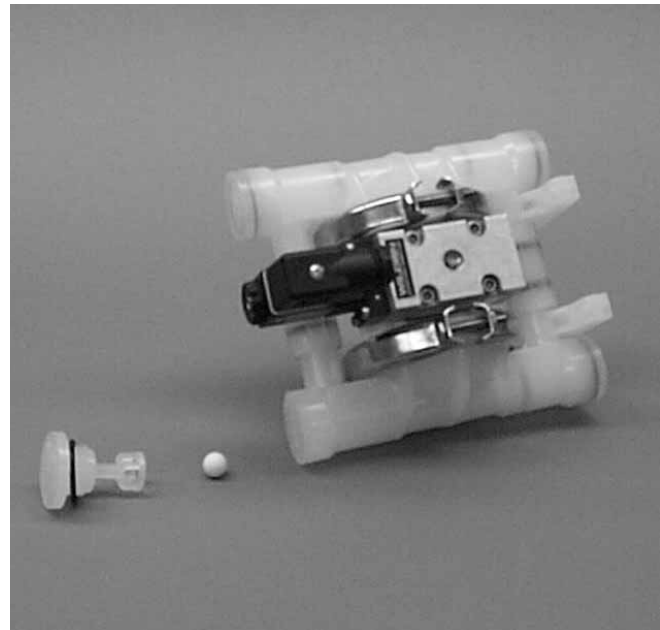

Step 3.

Figure 3

Inspect the ball retainer, retainer o-ring, and valve ball. Check for nicks, gouges, chemical attack or abrasive wear. Replace worn parts with genuine Wilden parts for reliable performance. Repeat Step 2 for remaining top retainer.

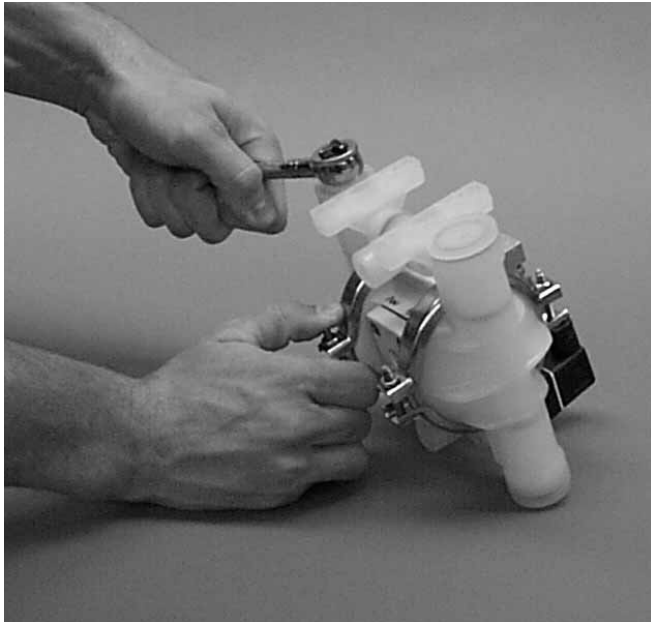

Step 4. *Figure 4*
Remove the bottom retainers with a 1/4" socket wrench.

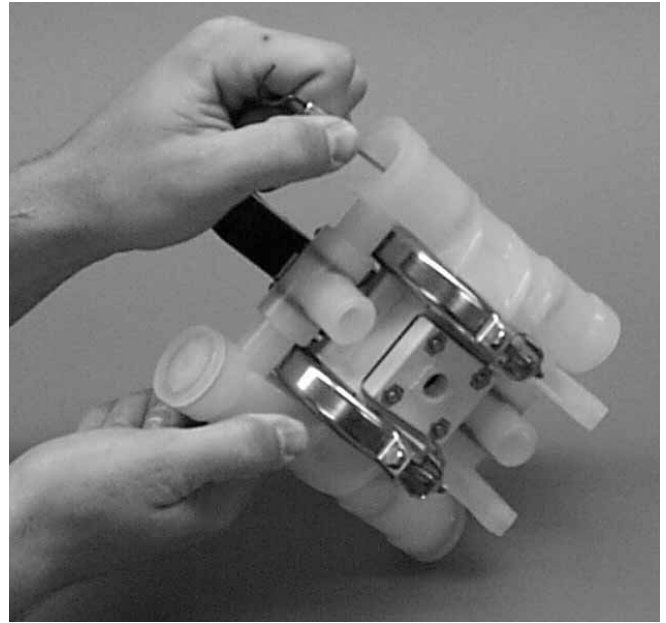

Step 5. *Figure 5*
To remove top and bottom valve seats, use a 3/8" rod and gently push or tap the seats out. Inspect seats for wear and replace with genuine Wilden parts if necessary.

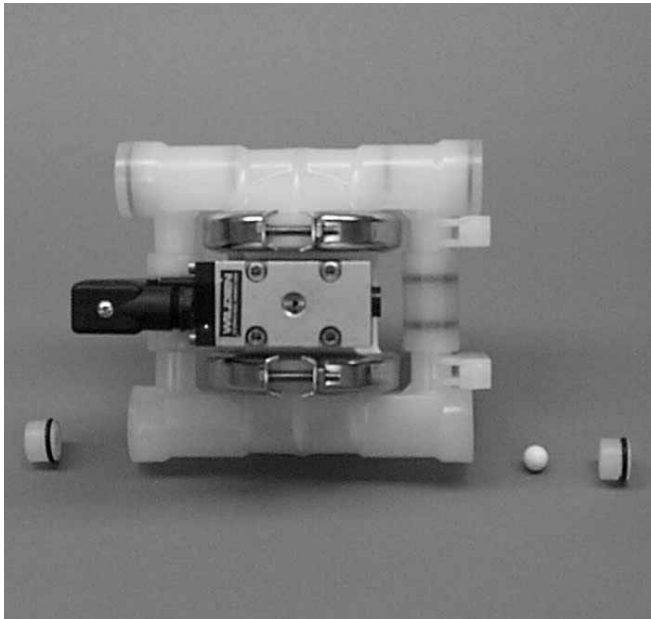

Step 6. *Figure 6*
Inspect the valve seat, valve seat o-ring, and valve ball. Check for nicks, gouges, chemical attack or abrasive wear. Replace worn parts with genuine Wilden parts for reliable performance.

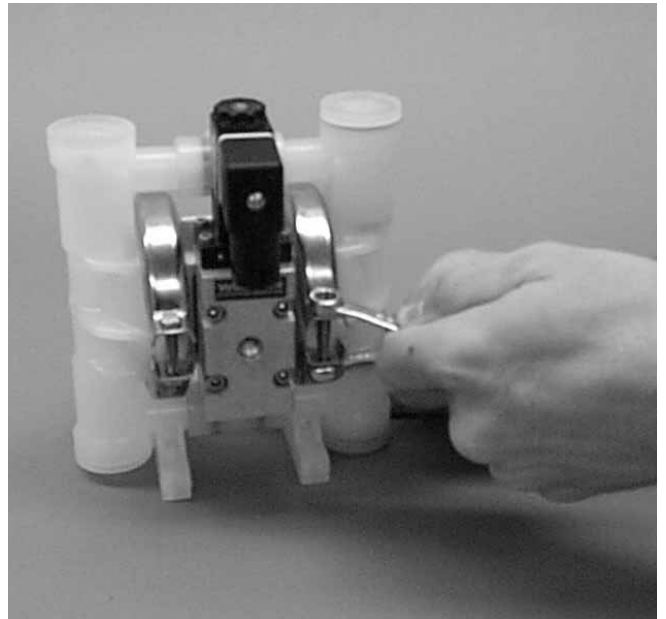

Step 7. *Figure 7*
Loosen clamp band with 3/8" box end wrench.

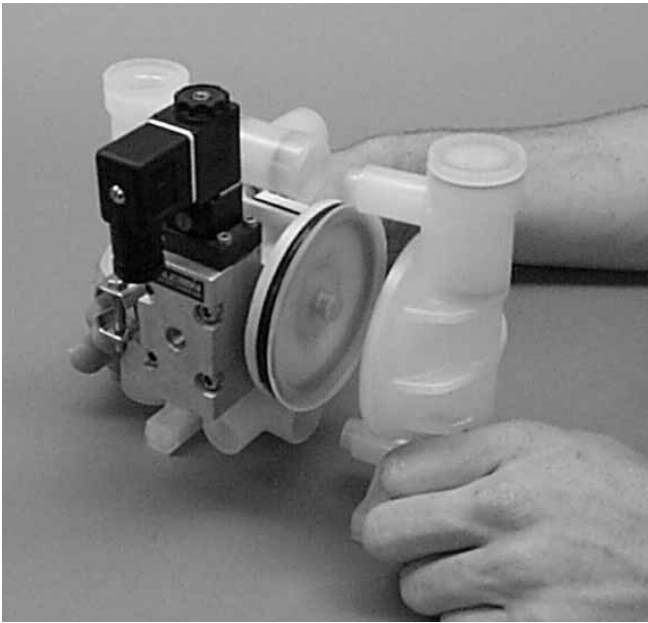

Step 8. *Figure 8*
After clamp bands are removed pull chambers apart.



Step 9. *Figure 9*
Carefully remove tee-section o-ring. Inspect o-ring for wear and replace with genuine Wilden parts if necessary.

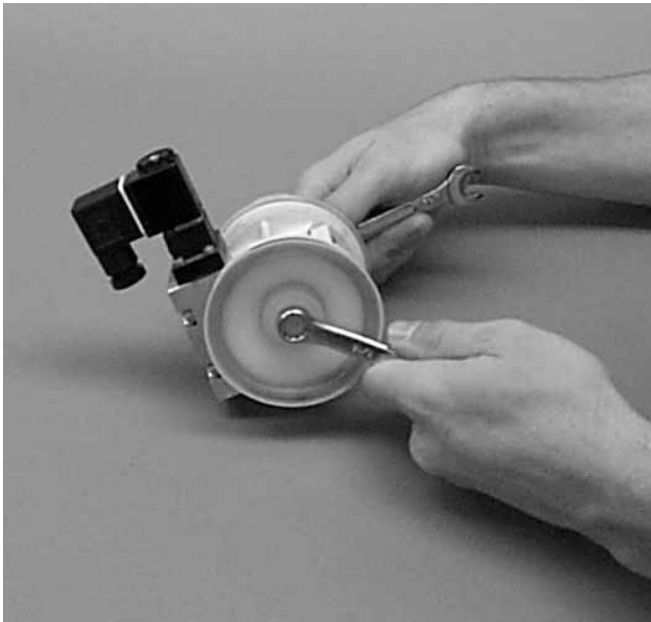

Step 10. *Figure 10*
Remove outer piston with 7/16" wrench if Rubber/TPE-fitted pump. For PTFE diaphragms, remove diaphragm by turning in a counter-clockwise direction.

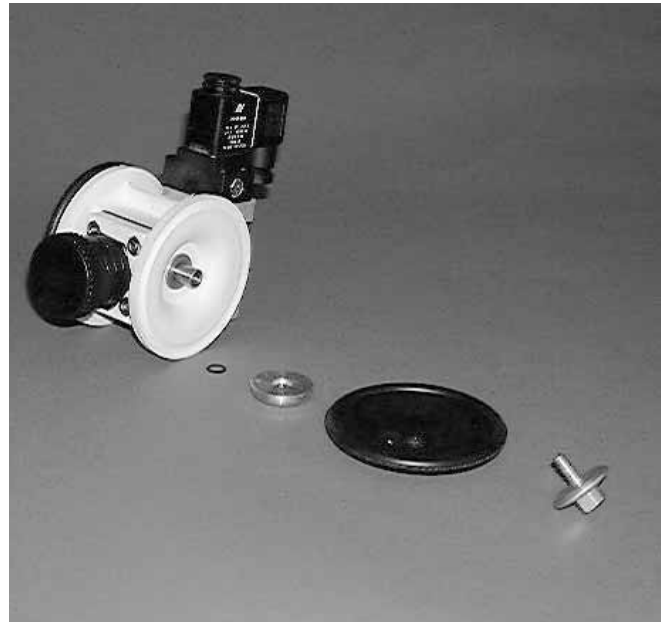

Step 11. *Figure 11*
Inspection of diaphragms, pistons, disc spring and shaft is now possible. **NOTE:** PTFE fitted pumps utilize a back up o-ring. Inspect all parts for wear and replace with genuine Wilden parts if necessary.

SECTION 8B

REASSEMBLY HINTS & TIPS

ASSEMBLY:

Upon performing applicable maintenance to the air distribution system, the pump can now be reassembled. Please refer to the disassembly instructions for photos and parts placement. To reassemble the pump, follow the disassembly instructions in reverse order. The air distribution system needs to be assembled first, then the diaphragms and finally the wetted path. Please find the applicable torque specifications on this page. The following tips will assist in the assembly process.

- Clean the inside of the center section shaft bushing to ensure no damage is done to new seals.
- Stainless bolts should be lubed to reduce the possibility of seizing during tightening.
- Do not leave tee-section o-rings in tee during reassembly. Place o-ring on male liquid chamber to ensure o-rings are not damaged and to facilitate easier assembly.
- Apply a small amount of Loctite 242 to the bore of the shaft from the diaphragm assembly.

TORQUE SPECIFICATIONS FOR MODEL A.025 PUMPS

Description of Part	Maximum Torque
Air Valve, Turbo-Flo™ Solenoid	2.3 N•m (20 in-lbs)
Outer Piston, Rubber and TPE Diaphragms	5.6 N•m (50 in-lbs)
Air Valve, Pro-Flo®	2.3 N•m (20 in-lbs)
Clamp Band	2.3 N•m (20 in-lbs)
Top and Bottom Retainer, Poly	4.4 N•m (40 in-lbs)
Top and Bottom Retainer, PVDF	5.1 N•m (45 in-lbs)

Model A.025T Solenoid Operated — DC

Item	Part Description	Qty. per Pump	Polypropylene A.025T/PPPPA/0150	PVDF A.025T/KKPPA/0150
			P/N	P/N
1	24 Volt DC Valve Assembly ¹		00-2000-99-150	00-2000-99-150
2	Main Valve Body	1	00-2000-01-150	00-2000-01-150
3	24 Volt DC Coil	1	00-2110-99-150	00-2110-99-150
4	Terminal Connector	1	00-2130-99	00-2130-99
5	Air Valve Gasket — Buna-N	1	00-2600-52	00-2600-52
6	Air Valve Bolt	4	00-6000-03	00-6000-03
7	Air Valve Nut	4	01-6400-03	01-6400-03
8	Muffler Plate	1	00-3180-20	00-3180-20
9	Muffler Plate Gasket — Buna-N	1	00-3500-52	00-3500-52
10	Center Section	1	00-3150-20	00-3150-20
11	Center Block O-Ring	4	00-3200-52	00-3200-52
12	Shaft	1	00-3800-03	00-3800-03
13	Disc Spring	2	00-6800-08	00-6800-08
14	Inner Piston for Rubber/TPE	2	00-3700-01-150	00-3700-01-150
	PTFE-fitted	2	00-3750-01-150	00-3750-01-150
15	Outer Piston Rubber/TPE	2	00-4570-20	00-4570-21
	PTFE-fitted	2	00-3750-01-150	00-3750-01-150
16	Liquid Chamber	2	00-5001-20	00-5001-21
17	Manifold Tee-Section	2	00-5160-20	00-5160-21
18	Top Retainer	2	00-5411-20	00-5411-21
19	Bottom Retainer	2	00-5420-20	00-5420-21
20	Valve Seat	2	00-1130-20	00-1130-21
21	Back-up O-Ring* ²	2	00-1070-51	00-1070-51
22	Muffler	1	00-3510-99	00-3510-99
23	Valve Seat O-Ring*	2	*	*
24	Combo Retainer O-Ring*	2	*	*
25	Valve Ball*	4	*	*
26	Tee Section O-Ring*	4	*	*
27	Diaphragm*	2	*	*
28	Clamp Band Assembly	4	00-7300-03	00-7300-03
29	Clamp Band Bolt	4	01-6100-03	01-6100-03
30	Clamp Band Nut	4	01-6400-03	01-6400-03
31	Lock Washer ³	4	00-6770-03-514	00-6770-03-514
32	Flat Washer ³	4	00-6740-03-514	00-6740-03-514
33	Air Fitting ³	2	00-2170-20	00-2170-20
34	Adapter Block ³	1	**	**
	Vent Plug (not shown) ³		00-7020-17-514	00-7020-17-514

*Refer to Elastomer Options in Section 10.

**See Adapter Block Version

¹Air Valve Assembly includes items 2, 3, and 4.

²Part used only on PTFE-fitted pumps.

³Part used only on adapter block version.

All boldface items are primary wear parts.

Valve Assembly Options (Consists of Valve Body, Coil and Connector)

Pump Models Designating Specialty Code #	Part Number	Description
151	00-2000-99-151	24V AC / 12V DC Valve Assembly
153	00-2000-99-153	24V AC / 12V DC Valve Assembly (NEMA 7)
150	00-2000-99-150	24V DC Valve Assembly
154	00-2000-99-154	24V DC Valve Assembly (NEMA 7)
157	00-2000-99-157	24V DC Valve Assembly ¹
155	00-2000-99-155	110V AC Valve Assembly
156	00-2000-99-156	110V AC Valve Assembly (NEMA 7)

Item 1 Main Valve Body Options

Part Number	Description
00-2000-01-150	Main Valve Body
00-2000-01-154	Main Valve Body (NEMA 7)

Adapter Block Options

Part Number	Description
00-2150-13	Acetal
00-2150-20	Polypropylene
00-2150-32	UHMW PE

Item 2 Coil Options

Pump Models Designating Specialty Code #	Part Number	Description
150	00-2110-99-150	24V DC Coil
151	00-2110-99-151	24V AC Coil
153	00-2110-99-153	24V AC, NEMA 7 Coil
154	00-2110-99-154	24V DC, NEMA 7 Coil
155	00-2110-99-155	110V AC Coil
156	00-2110-99-156	110V AC NEMA 7 Coil
157	00-2110-99-157	International 24V DC Coil ⁵

EXPLODED VIEW/PARTS LISTING

A.025P

SOLENOID-OPERATED

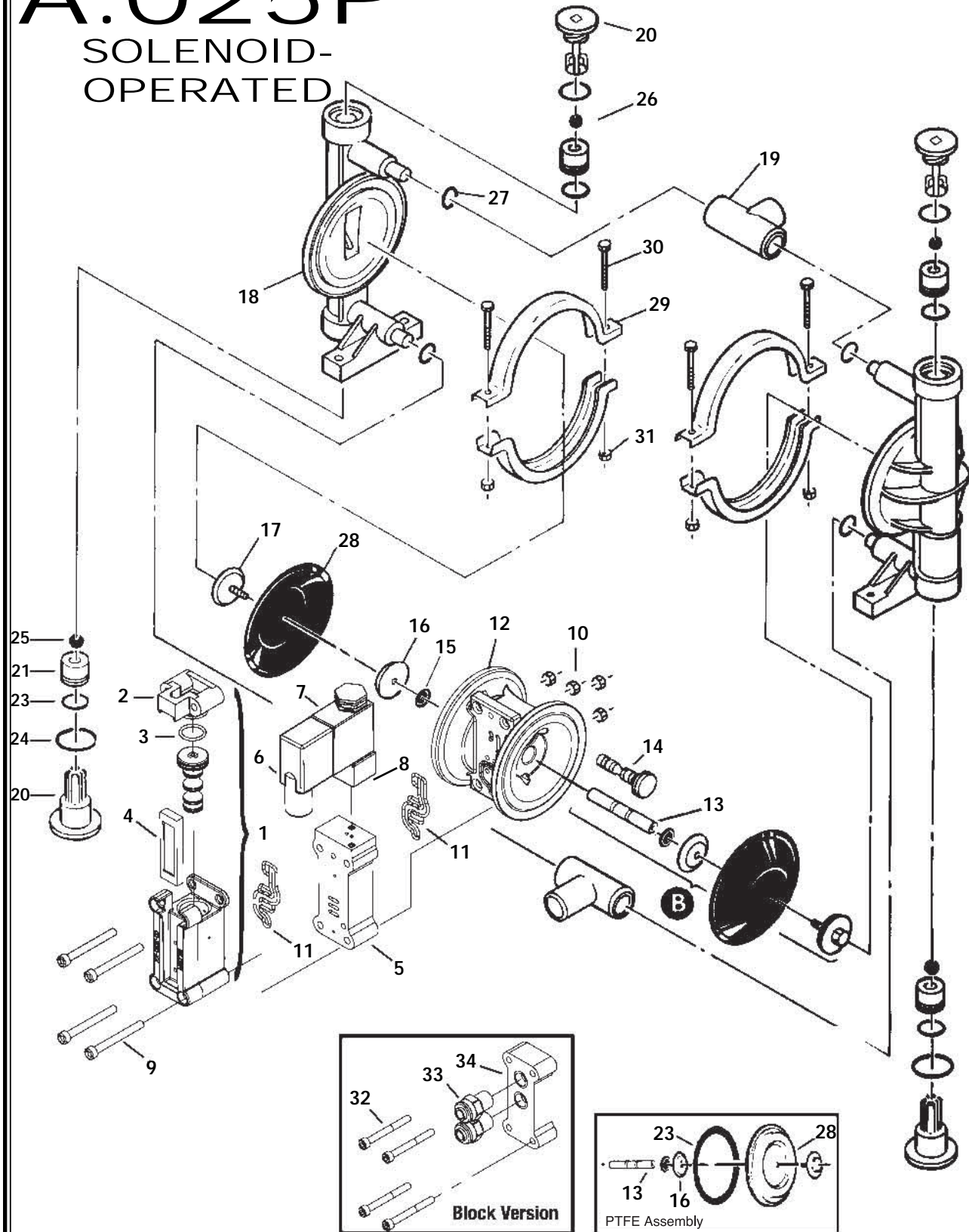

A.025P Solenoid Operated — DC

Item	Part Description	Qty. per Pump	Polypropylene A.025P/PPPPA/0150	PVDF A.025P/KKPPA/0150
			P/N	P/N
1	Pro-flo® Air Valve Assembly	1	00-2000-20-700	00-2000-20-700
2	Pro-flo® Air Valve End Cap	1	00-2300-20-700	00-2300-20-700
3	End Cap O-Ring	1	00-2390-52-700	00-2390-52-700
4	Muffler Element	1	00-3240-26-700	00-3240-26-700
5	Pro-Flo® Solenoid Spacer	1	00-2160-20	00-2160-20
6	Terminal Connector	1	00-2130-99	00-2130-99
7	24 Volt DC Coil	1	00-2110-99-150	00-2110-99-150
8	Solenoid Operator	1	00-2122-99	00-2122-99
9	Air Valve Bolt	4	00-6000-03	00-6000-03
10	Air Valve Nut	4	01-6400-03	01-6400-03
11	Air Valve Gasket	2	00-2600-52-700	00-2600-52-700
12	Center Section	1	00-3150-20-700	00-3150-20-700
13	Shaft	1	00-3800-99-700	00-3800-99-700
14	Pilot Plug Assembly	1	00-2285-99	00-2285-99
15	Disc Spring	2	00-6800-08	00-6800-08
16	Inner Piston for Rubber/TPE	2	00-3700-01-150	00-3700-01-150
16	PTFE-fitted	2	00-3750-01-150	00-3750-01-150
17	Outer Piston Rubber/TPE	2	00-4570-20	00-4570-21
17	PTFE-fitted	2	00-3750-01-150	00-3750-01-150
18	Liquid Chamber	2	00-5001-20	00-5001-21
19	Manifold Tee-Section	2	00-5160-20	00-5160-21
20	Top Retainer	2	00-5411-20	00-5411-21
21	Bottom Retainer	2	00-5420-20	00-5420-21
22	Valve Seat	2	00-1130-20	00-1130-21
23	Back-up O-Ring*2	2	00-1070-51	00-1070-51
24	Valve Seat O-Ring*	2	*	*
25	Combo Retainer O-Ring*	2	*	*
26	Valve Ball*	4	*	*
27	Tee Section O-Ring*	4	*	*
28	Diaphragm*	2	*	*
29	Clamp Band Assembly	4	00-7300-03	00-7300-03
30	Clamp Band Bolt	4	01-6100-03	01-6100-03
31	Clamp Band Nut	4	01-6400-03	01-6400-03
32	Air Valve Bolt, Adapter Block ³	4	00-6000-03-700	00-6000-03-700
33	Air Fitting ³	2	00-2170-20	00-2170-20
34	Adapter Block ³	1	**	**

*Refer to Elastomer Options in Section 10.

**See adapter block options.

¹Air Valve Assembly includes items 2, 3, and 4.

²Part used only on PTFE-fitted pumps.

³Part used only on adapter block version.

All boldface items are primary wear parts.

Valve Assembly Options (Consists of Valve Body, Coil and Connector)

Pump Models Designating Specialty Code #	Part Number	Description
151	00-2000-99-151	24V AC / 12V DC Valve Assembly
150	00-2000-99-150	24V DC Valve Assembly
157	00-2000-99-157	International 24V DC Valve Assembly ¹
155	00-2000-99-155	110V AC Valve Assembly

¹NEMA7 Not available on A.025P pumps

Item 1 Main Valve Body Options

Part Number	Description
00-2000-01-150	Main Valve Body

Adapter Block Options

Part Number	Description
00-2155-13	Acetal
00-2155-20	Polypropylene

Item 2 Coil Options

Pump Models Designating Specialty Code #	Part Number	Description
150	00-2110-99-150	24V DC Coil
151	00-2110-99-151	24V AC Coil
154	00-2110-99-154	24V DC, NEMA 7 Coil
155	00-2110-99-155	110V AC Coil
157	00-2110-99-157	International 24V DC Coil ¹

¹Meets European standards and regulations, Cenelec/PTB file #EX-91.C.2027

SECTION 10A

ELASTOMER OPTIONS

A.025

Material	Valve Seat O-Ring	Combo Retainer O-Ring	Valve Ball	Tee Section O-Ring	Diaphragm	Backup Diaphragm O-Ring
Wii-Flex™	00-1200-58	00-1260-58	N/A	00-1300-58	00-1010-58	00-1070-58
Buna-N	00-1200-52	00-1260-52	N/A	00-1300-52	00-1010-52	N/A
PTFE	N/A	N/A	00-1080-55	N/A	00-1030-55	N/A
PTFE-Encapsulated Viton®	00-1200-60	00-1260-60	N/A	00-1300-60	N/A	N/A
Neoprene	N/A	N/A	N/A	N/A	N/A	00-1070-51

SECTION 10B

ELECTRICAL INFORMATION

NEMA 4¹ / UL / CSA

Part Number	Voltage ±10%			Power (W) ±10%	Current (A)			Resistivity (Ω)
	DC	AC			DC	AC		
		60 Hz	50 Hz			Inrush	Holding	
00-2110-99-150	24	48	44	4.8	.20	.20	.20	121
00-2110-99-151	12	24	22	4.8	.40	.40	.40	32
00-2110-99-155	60	120	110	4.8	.08	.08	.06	840

NEMA 7 / UL / CSA

Part Number	Voltage ±10%			Power (W) ±10%	Current (A)			Resistivity (Ω)
	DC	AC			DC	AC		
		60 Hz	50 Hz			Inrush	Holding	
00-2110-99-153	12	24	22	7	.60	.55	.32	19
00-2110-99-154	24	48	44	7	.30	.30	.18	75
00-2110-99-156	60	120	110	7	.12	.13	.06	475

INTERNATIONAL EXPLOSION PROOF / CENELEC / PTB FILE # EX-91.C.2027

Part Number	DC Voltage ±10%	Power (W) ±10%	Current (A)		Resistivity (Ω)
			Inrush	Holding	
00-2110-99-153	24	3.3	.135	.135	177

¹NEMA 4 and IEC 144/855420 I.P. 66 for "Dust-tight, watertight corrosion resistant."

²Meets European standards and regulations, Cenelec/PTB file # EX-91.C.2027.

WARRANTY

Each and every product manufactured by Wilden Pump and Engineering, LLC is built to meet the highest standards of quality. Every pump is functionally tested to insure integrity of operation.

Wilden Pump and Engineering, LLC warrants that pumps, accessories and parts manufactured or supplied by it to be free from defects in material and workmanship for a period of five (5) years from date of installation or six (6) years from date of manufacture, whichever comes first. Failure due to normal wear, misapplication, or abuse is, of course, excluded from this warranty.

Since the use of Wilden pumps and parts is beyond our control, we cannot guarantee the suitability of any pump or part for a particular application and Wilden Pump and Engineering, LLC shall not be liable for any consequential damage or expense arising from the use or misuse of its products on any application. Responsibility is limited solely to replacement or repair of defective Wilden pumps and parts.

All decisions as to the cause of failure are the sole determination of Wilden Pump and Engineering, LLC.

Prior approval must be obtained from Wilden for return of any items for warranty consideration and must be accompanied by the appropriate MSDS for the product(s) involved. A Return Goods Tag, obtained from an authorized Wilden distributor, must be included with the items which must be shipped freight prepaid.

The foregoing warranty is exclusive and in lieu of all other warranties expressed or implied (whether written or oral) including all implied warranties of merchantability and fitness for any particular purpose. No distributor or other person is authorized to assume any liability or obligation for Wilden Pump and Engineering, LLC other than expressly provided herein.

PLEASE PRINT OR TYPE AND FAX TO WILDEN

PUMP INFORMATION			
Item # _____		Serial # _____	
Company Where Purchased _____			
YOUR INFORMATION			
Company Name _____			
Industry _____			
Name _____		Title _____	
Street Address _____			
City _____	State _____	Postal Code _____	Country _____
Telephone _____	Fax _____	E-mail _____	Web Address _____
Number of pumps in facility? _____		Number of Wilden pumps? _____	
Types of pumps in facility (check all that apply): <input type="checkbox"/> Diaphragm <input type="checkbox"/> Centrifugal <input type="checkbox"/> Gear <input type="checkbox"/> Submersible <input type="checkbox"/> Lobe			
<input type="checkbox"/> Other _____			
Media being pumped? _____			
How did you hear of Wilden Pump? <input type="checkbox"/> Trade Journal <input type="checkbox"/> Trade Show <input type="checkbox"/> Internet/E-mail <input type="checkbox"/> Distributor			
<input type="checkbox"/> Other _____			

ONCE COMPLETE, FAX TO (909) 783-3440

NOTE: WARRANTY VOID IF PAGE IS NOT FAXED TO WILDEN

WILDEN PUMP & ENGINEERING, LLC